

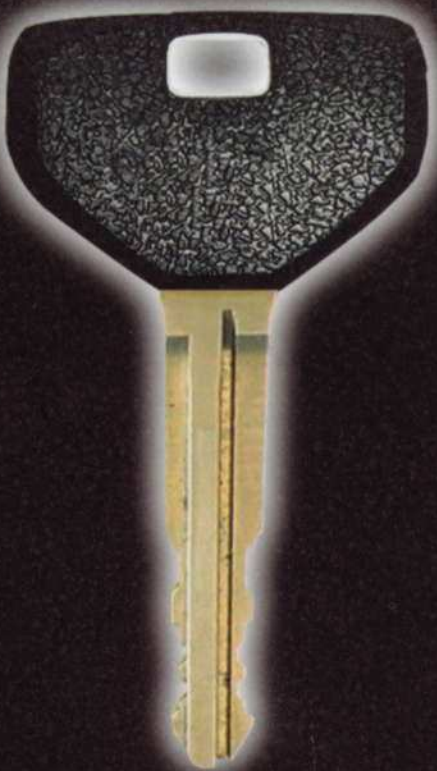

User's manual



ATV3000-18

PREFACE

Thank you for purchasing our vehicle, and welcome to our world-wide family of BASHAN owners. We proudly produce an exciting line of utility and recreational products. We believe BASHAN sets a standard of excellence for all utility and recreational vehicles manufactured in the world today. Many years of experience have gone into the engineering, design, and development of our ATV, making it the finest machine we've ever produced.

For safe and enjoyable operation of your vehicle, be sure to follow the instructions and recommendations in this owner's manual. Your manual contains instructions for minor maintenance, ATV specifications, and drive safety. Due to this manual you can know necessary skill of ATV driving. Otherwise owners may find out parts you need out of part's shape, name, coding or composed relationships through this manual, but for our products are in continue developing, can this make some difference between real object and image, please according to real object.

Table of contents Index

IMPORTANT SAFETY INFORMATION		
ONE.		
1.warning	1	
2.Prohibition	1	
3.warning sticker	1	
4.safety riding equipment	2	
5.knowledge of vehicle	3	
6.safety training	4	
TWO.SAFETY		
1. Tire	4	
2. Filter	4	
3.driving	4	
4.breaks	5	
THREE. Potential hazard and how to avoid.		
FOUR. control system		
1.location of vehicle parts	16	
2.power switch	17	
3.left operation bar	17	
4.accelerator controller	18	
5.auxiliary brake lever	18	
6.main brake	18	
7.parking brake	20	
8.fuel cock, filter	21	
9.gearshift settings	21	
10.instrument cluster	21	
FIVE.OPERATION		
11. carburetor	22	
12.battery	23	
13. engine cooling system	23	
14. air filter	23	
FIVE.OPERATION		
1.fuel	24	
2. engine break-in and lubrication	25	
3.pre-riding inspection	25	
4. starting engine	27	
5.tire installation	28	
SIX. driving safety		
1. loaded riding	29	
2. making turns	30	
3.driving on slippery surface	30	
4.Climbing a hill	31	
5. lateral riding	31	
6. down hill riding	31	
7. Turning on slope	32	
8. wade riding	32	
9.obstacle riding	32	
10. reverse driving	32	
11.parking on the slope	32	
SEVEN.maintenance and lubrication		
1. lubrication oil type	36	
2.oil check	36	
3.oil changing way and steps	36	

4. transitions chain lubrication	37
5. engine cooling system maintenance	37
9. parts catalogue coding check list	39
6. brake system maintenance	40
7.F./R. tire maintenance	40
8. Battery	41
EIGHT. cleaning, storage, transportation	42
1. Cleaning	42
2. Storage	42
3. Transportation	43
NINE. fault inspection and maintenance	44
TEN. parameter	45
ELEVEN. electric principle diagram	46
TWELVE. parts catalogue	47
1. Frame	47
2. front wheel	48
3. steering stem	49
4. Covering	50
5. rear wheel	51
6. engine	52
7. rear bridge dismantle	53
8. engine exploded view	54
9. parts catalogue coding check list	68
10. engine parts catalogue coding check list	76

IMPORTANT SAFETY INFORMATION

● WARNING

Improperly riding vehicle may cause severe injury or death.

Always use an approved helmet and protective gear, otherwise it may cause severe injury or death.

Never operate an ATV on a public street, road or highway, including a dirt or gravel road.

Never carrying a passenger on an ATV, it could result in loss of control and accident.

Never operating the ATV after consuming alcohol or drugs, it may cause hallucination, distraction and disability and result in an accident.

Never drive under bad spirit and tired situation.

The engine exhaust from this product contains chemicals known to cause cancer or other reproductive harm.

So never start the engine or let it run in an enclosed area.

Properly riding to avoid vehicle overturns on hills and rough terrain, and in turns.

Avoid paved surfaces, which may adversely affect handling and control.

● PROHIBITED

PROHIBITED: Operate without proper training or instruction.

PROHIBITED: Operate on public highway. A collision can occur with another vehicle.

PROHIBITED: Operate at speed beyond your skills or the conditions.

PROHIBITED: Take ALCOHOL or DRUGS before or while operating this vehicle.

PROHIBITED: Carry Passengers.

PROHIBITED: Drive in tired condition or bad spirit.

PROHIBITED: Start the engine or let it run in an enclosed area.

PROHIBITED: Never allow anyone under 16 years of age to operate this ATV.

WARNING STICKER

Warning stickers shall be placed on left and right side of the ATV for your protection.

Read and follow the instructions of the decals on the ATV carefully. If any of the decals depicted in this manual differs from the decals on your ATV, always read and follow the instructions of the decals on the ATV.

The safety alert warning indicates a potential hazard that may cause serious injury or death.

The safety alert caution indicates a potential hazard that may cause minor injury or damage to the vehicle.

Serious injury or death can result if you do not follow these instructions and procedures, which are outlined in further detail within your

owner's manual.

Never operate an ATV without proper instruction. Please take a training course about ATV.

Never permit a guest to operate the ATV unless the guest has read this manual and all product labels and has completed a certified safety training course.

Never operate an ATV without wearing an approved helmet that fits properly. Always wear eye protection (goggles or face shield), gloves, boots, a long-sleeved shirt or jacket, and long pants.

Never consume alcohol or drugs before or while operating an ATV.

Always avoid riding an ATV on paved surfaces, including pavillion, driveways, parking lots, and express way.

Never operate at excessive speed. Travel at speed appropriate for the terrain, visibility and operating conditions, and your experience.

Never attempt wheelies, jumps or other stunts.

Always check your ATV make sure it is in normal operating condition before operating. Always follow the inspection and maintenance procedures and schedules outlined in your owner's manual.

Always keep both hands on the handlebars and both feet on the footrests of the ATV during operation.

Always travel slowly with extra caution while operating on unfamiliar terrain. Be alert to changing terrain conditions.

Never operate on excessively rough, slippery or loose terrain.

Safe riding gear

helmet

Your helmet is the most important safety unit of protective gear for riding. A helmet can prevent a severe head injury. Select an approved helmet that meets safety standards in your state.

Clothing

Always wear clothing suited for riding. Riding ATV requires special protective clothing for comfort and to reduce the chance of injury.

Always wear long sleeves and long trousers to protect arms and legs. Riding trousers with kneepads and a jersey with shoulder pads provide the best protection.

Eye protection

Do not depend on sunglasses for proper eye protection. A pair of goggles or a helmet face shield offers the best protection for your eyes. They should be kept clean and be of shatterproof design

Gloves

Off-road style gloves with knuckle pads are the best for comfort and protection.

Boots

The best footwear is a pair of strong over-the-calf boots with heels, like motor-cross boots.

● Know your vehicle

As the operator of the vehicle, you shall be responsible for your personal safety, the safety of others, and the protection of our environment. Read and understand your owner's manual, which includes valuable information about all aspects of your vehicle, including safe operating procedures.

This ATV is not a toy. It is much more difficult to operate than other vehicles, such as motorcycles and cars. A collision or rollover can occur quickly, even during routine maneuvers like turning, or driving on hills or over obstacles, if you fail to take proper precautions.

This vehicle is an **ADULT VEHICLE ONLY**. Operation is prohibited for anyone under 16 years old.

Safe training

When you purchase your new ATV, your dealer will offer a hands-on safety training course that covers all aspects of vehicle safety. You were also provided with printed materials that explain safe operating procedures. You should review this information on a regular basis.

This is an off-road vehicle. Be familiar with all the laws and regulations concerning the operation of the ATV in your area.

We strongly advise you to strictly follow the recommended maintenance procedure outlined in your owner's manual. This preventive maintenance program is designed to ensure that all critical components on your vehicle are thoroughly inspected at specific intervals.

Operator safety

●TIRE

Loading capacity: INCLUDE DRIVER, LOAD, VEHICLE, TOTALLY 400KG
TIRE PRESSURE: FRONT 100KPa REAR 100KPa

WARNING

Improper tire pressure or overloading can cause loss of control resulting in severe injury or death.

loading

Reduce speed and allow greater distance for braking while carrying cargo. Overloading or carrying tall, off-center, or unsecured loads will increase your risk of losing control. Loads should be centered, carried as low as possible, and firmly secured to the racks. With dual racks, load distribution 1/3 front 2/3 rear is best. For stability on rough or hilly terrain, reduce speed and cargo. Do not block headlight. Be careful if load extends over the side of the rack.

Rack loads (IF HAVE RACK) : FRONT 20KG, REAR 40KG

Do not tow from rack or bumper. Vehicle damage or tip over may cause severe injury or death. Tow only from tow hooks or hitch.

●Air cleaning filter

WARNING

Operation of this vehicle without the air filter element will severely damage the engine.

Clean pre-filter element often, more frequently cleaning required in dusty conditions. Do not operate vehicle before cleaning.

Operation of this vehicle without engine breather filter(s) can cause engine damage. Consult owner's manual or dealer for details.

●DRIVING ATTENTION:

Never operate on hills too steep for the ATV or for your abilities Practice on smaller hills before attempting larger hills.

Always follow proper procedures for climbing hills, Check the terrain carefully before ascending a hill. Never climb hills with excessively slippery of loose surfaces. Keep your weight forward. Never open the throttle suddenly or make sudden gear changes. Never go over the top of a hill at high speed.

Always follow proper procedures for going downhill and for braking on hills. Check the terrain carefully before you ride down a hill. Keep

your weight backward. Never go down a hill at high speed. Avoid going down a hill at an angle, which would cause the vehicle to lean sharply to one side. Travel straight down the hill when possible.

Always follow proper procedures for crossing the side of a hill. Avoid hills with excessively slippery or loose surfaces. Keep your weight to the uphill side of the ATV. Never attempt to turn the ATV around on any hill until you've mastered (on level ground) the turning skill outlined in this manual. Avoid crossing the side of a steep hill when possible.

Always follow proper procedures if you stall or roll backwards while climbing a hill. To avoid stalling, maintain a steady speed when climbing a hill. If you stall or roll backwards, follow the special procedure for braking described in this manual. Always dismount on the uphill side, or to either side if the ATV is pointed straight uphill. Turn the ATV around and remount following the procedure described in this manual.

Never attempt to operate over large obstacles, such as rocks or fallen trees. Always follow proper procedures when operating over obstacles as described in this manual.

Always be careful of skidding or sliding. On slippery surfaces like ice, travel slowly with extra caution to reduce the chance of skidding or sliding out of control.

Avoid operating the ATV through deep or fast-flowing water. If it's unavoidable, travel slowly, balance your weight carefully, avoid sudden movements, and maintain a slow and steady forward motion. Don't make sudden turns of stops, and do not make sudden throttle changes.

Always check for obstacles or people behind the ATV before operating in reverse. When it's safe to proceed in reverse, move slowly and avoid turning at sharp angles.

Instruction to using brake

Wet brakes may have reduced stopping ability. Always check the brakes after leaving water. If necessary, apply them several times to let friction dry out the pads.

Reduce speed when carrying cargo or pulling a trailer. Based on manual allow a greater distance for braking.

Modification Attention

We are concerned for the safety of our customers and for the general public. Therefore, we strongly recommend that consumers do not install on an ATV any equipment that may increase the speed or power of the vehicle, or make any other modifications to the vehicle for these purposes. Any modifications to the original equipment of the vehicle create a substantial safety hazard and increase the risk of bodily injury.

The warranty on your ATV is terminated if any equipment has been added to the vehicle, or if any modifications have been made to the vehicle.

NOTE: The addition of certain accessories, including (but not limited to) mowers, blades, tires, sprayers, or large racks, may change the

handling characteristics of the vehicle. Adopt only approved accessories of our company, and familiarize yourself with their function and effect on the vehicle.

POTENTIAL HAZARD and HOW TO AVOID THE HAZARD

WARNING

POTENTIAL HAZARD: Operating this ATV without following instruction

WHAT CAN HAPPEN

The risk of an accident is greatly increased if the operator does not know how to operate the ATV properly in different situations and on different types of terrain.

HOW TO AVOID THE HAZARD

Beginning and inexperienced operators should complete the certified training course offered by dealer. Operators should regularly practice the skills learned in the course and the operating skill described in the owner's manual.

WARNING

POTENTIAL HAZARD: Carrying a passenger on an ATV.

WHAT CAN HAPPEN

Carrying a passenger greatly reduces the operator's ability to balance and control the ATV, which could cause an accident and injury to the operator and/or passenger.

HOW TO AVOID THE HAZARD

Never carry a passenger. The purpose of the long seat is to allow the operator to shift position as needed during operation. It is not intended for carrying passengers.

WARNING

POTENTIAL HAZARD: Failure to follow the age recommendations for this ATV.
RISK

Severe injury and/or death could occur if a child under the minimum age recommendation operates an ATV. Even though a child may be within the recommended age group for operating some ATVs, he/she may not have the skills, abilities, or judgment needed to operate an ATV safely and could be susceptible to accident or injury.

HOW TO AVOID THE HAZARD

No one under the age of 16 should operate a ATV

WARNING

POTENTIAL HAZARD: Operating this ATV on public streets, roads or highway.

WHAT CAN HAPPEN

The ATV could collide with another vehicle.

HOW TO AVOID THE HAZARD

Never operate the ATV on any public street, road or highway, including dirt and gravel roads. In many areas and countries it's illegal to operate ATVs on public streets, roads and highways.

WARNING

POTENTIAL HAZARD: Operating an ATV on paved surfaces, including sidewalks, paths, parking lots, and driveways.

WHAT CAN HAPPEN

ATV tires are designed for off-road use. Operating on paved surfaces may seriously affect the handling and control of the ATV and could result in loss of control, accident, and /or injury.

HOW TO AVOID THE HAZARD

Avoid operating the ATV on pavement. If it's unavoidable, travel slowly and avoid sudden turns or stops.

WARNING

POTENTIAL HAZARD: Operating this ATV without wearing an approved helmet, eye protection and protective clothing.

WHAT CAN HAPPEN

Operating an ATV without an approved helmet increases the risk of a severe head injury or death in the event of an accident. Operating without eye protection could result in an accident and could increase the chance of a severe injury in the event of an accident.

HOW TO AVOID THE HAZARD

Always wear an approved helmet that fits properly. Always wear eye protection (goggles or face shield), gloves, boots, long-sleeved shirt or jacket, and long pants.

WARNING

POTENTIAL HAZARD: Operating the ATV after consuming alcohol or drugs.

WHAT CAN HAPPEN

Consumption of alcohol and/or drugs could seriously affect operator judgment. Reaction time may be slower and operator balance and perception could be affected. IT could result in an accident causing severe injury or death.

HOW TO AVOID THE HAZARD

Never consume alcohol or drugs before or while operating an ATV.

WARNING

POTENTIAL HAZARD: Operating the ATV at excessive speeds.

WHAT CAN HAPPEN

Excessive speed increases the operator's chance of losing control of the ATV, which can result in an accident.

HOW TO AVOID THE HAZARD

Always operate the ATV at a speed that's proper for the terrain, visibility and operating conditions, and your experience.

WARNING

POTENTIAL HAZARD: Attempting wheelies, jumps and other stunts.

WHAT CAN HAPPEN

Attempting stunts increases the chance of an accident, including an overturn.

HOW TO AVOID THE HAZARD

Never attempt wheelies, jumps, or other stunts. Avoid exhibition driving.

WARNING

POTENTIAL HAZARD: Failure to inspect the ATV before operating.

WHAT CAN HAPPEN

Poor maintenance increases the possibility of an accident or equipment damage.

HOW TO AVOID THE HAZARD

Always inspect your ATV especially ensure fastener nuts tightness of important parts before each use to make sure it's in safe operating condition.

WARNING

POTENTIAL HAZARD: Removing hands from the handlebars or feet from the footrests during operation.

WHAT CAN HAPPEN

Removing even one hand or foot can reduce ability to control the vehicle or could cause loss of balance and ejection from the ATV. If the operator's foot is not firmly planted on the footrest, it could come into contact with the rear wheels and lead to accident or injury.

HOW TO AVOID THE HAZARD

Always keep both hands on the handlebars and both feet on the footrests of the ATV during operation.

WARNING

POTENTIAL HAZARD: Failure to use extra caution when operating the ATV on unfamiliar terrain.

WHAT CAN HAPPEN

Unfamiliar terrain may contain hidden rocks, bumps, or holes that could cause loss of control or overturn and lead to accident or injury.

HOW TO AVOID THE HAZARD

Travel slowly and use extra caution when operating on unfamiliar terrain, always be alert to changing terrain conditions.

WARNING

POTENTIAL HAZARD:

Failure to use extra caution when operating on excessively rough, slippery or loose terrain.

WHAT CAN HAPPEN

Operating on excessively rough, slippery or loose terrain could cause loss of traction or loss of control, which could result in an accident or overturn.

HOW TO AVOID THE HAZARD

Do not operate on excessively rough, slippery or loose terrain until you're learned and practiced the skills necessary to control the ATV on such terrain.

WARNING

POTENTIAL HAZARD: Turning improperly

WHAT CAN HAPPEN

Improper turns could cause loss of control and lead to a collision or overturn.

HOW TO AVOID THE HAZARD

Always follow proper procedures for turning as described in the owner's manual. Practice turning at slow speeds before attempting to turn at faster speeds. Never turn at excessive speed.

WARNING

POTENTIAL HAZARD: Operating on excessively steep hills.

WHAT CAN HAPPEN

The vehicle may overturn.

HOW TO AVOID THE HAZARD

Never operate on hills too steep for the ATV of for your abilities.

Never operate the ATV on hills steeper than 20°. Practice on smaller hills before attempting large hills.

WARNING

POTENTIAL HAZARD: Climbing hills improperly.

WHAT CAN HAPPEN

Improper hill climbing could cause loss of control or overturn.

HOW TO AVOID THE HAZARD

Always follow proper procedures for climbing hills as described in the owner's manual.

Always check the terrain carefully before ascending any hill.

Never operate the ATV on hills steeper than 20°.

Never climb hills with excessively slippery or loose surfaces. Shift your weight forward.

Never open the throttle suddenly while traveling uphill. The ATV could flip over backwards.

Never go over the top of any hill at high speed. An obstacle, a sharp drop, or another vehicle or person could be on the other side of the hill.

WARNING

POTENTIAL HAZARD:

Traveling downhill improperly.

WHAT CAN HAPPEN

Improperly descending a hill could cause loss of control or overturn and lead to injury or death.

HOW TO AVOID THE HAZARD

A special technique is required when braking while traveling downhill.

Always check the terrain carefully before descending a hill. Shift your weight backward. Never travel down a hill at high speed.

Avoid traveling down a hill at an angle, which would cause the vehicle to lean sharply to one side. Travel straight down the hill when possible.

WARNING

POTENTIAL HAZARD: Improperly crossing hills and turning on hills.

WHAT CAN HAPPEN

Improperly crossing or turning as hills could cause loss of control or overturn and lead to injury or death.

HOW TO AVOID THE HAZARD

Never attempt to turn the ATV around on any hill until you've mastered the turning technique as described in the owner's manual. Use extra caution when turning on any hill. Avoid crossing the side of a steep hill.

Avoid hills with excessively slippery or loose surfaces.

WARNING

POTENTIAL HAZARD:

Stalling, rolling backwards of improperly dismounting while climbing a hill.

WHAT CAN HAPPEN

The vehicle could cause loss of control or overturn and lead to injury or death.

HOW TO AVOID THE HAZARD

Keep steady speed when climbing a hill. If all forward speed is lost, keep your weight uphill.

If ATV begins rolling backwards, apply the brakes.

Lock the parking brake when fully stopped.

If the ATV begins rolling backwards, keep weight uphill; never apply engine power; never apply the rear brake while rolling backwards.

Apply the single-lever brake gradually.

When fully stopped, apply the rear brake as well, and then lock the parking brake,

Dismount on uphill side, or to either side if ATV is pointed straight uphill.
Turn the ATV around and remount.

WARNING

POTENTIAL HAZARD: Improperly operating over obstacles.

WHAT CAN HAPPEN

Operating over obstacles could cause loss of control or overturn and lead to injury or death.

HOW TO AVOID THE HAZARD

Before operating in a unfamiliar area, check for obstacles. Avoid operating over large obstacles such as rocks and fallen trees if possible. If unavoidable, take extreme caution and always follow proper procedures as outlined in the owner's manual.

WARNING

POTENTIAL HAZARD: Skidding or sliding.

WHAT CAN HAPPEN

Skidding or sliding can cause loss of control. If the tires regain traction unexpectedly, the ATV could overturn.

HOW TO AVOID THE HAZARD

Avoid skidding or sliding, on slippery surfaces such as ice, travel slowly and take extra caution to reduce the chance of skidding or sliding out of control.

WARNING

POTENTIAL HAZARD: Improperly operating in reverse.

WHAT CAN HAPPEN

The ATV could collide with an obstacle or person, resulting in severe injury.

HOW TO AVOID THE HAZARD

Before shifting into reverse gear, always check for obstacles or people behind the ATV. When it's safe to proceed, back slowly.

WARNING

POTENTIAL HAZARD: Operating the ATV through deep or fast-flowing water.

WHAT CAN HAPPEN:

Tires may float, causing loss of traction and loss of control, which could lead to an accident or overturn.

HOW TO AVOID THE HAZARD

Avoid operating the ATV through deep or fast-flowing water. If it's unavoidable to enter water that exceeds the recommended maximum depth, travel slowly, balance your weight carefully, avoid sudden movements, and maintain a slow and steady forward motion. Do not make sudden turns or stops, and do not make sudden throttle changes. Wet brakes may have reduced stopping ability. Always test the brakes after leaving water. If necessary, apply them several times to let friction dry out the pads.

WARNING

POTENTIAL HAZARD: Operating this ATV with improper tires, or with improper or uneven tire pressure.

WHAT CAN HAPPEN

It could cause loss of control or accident and resulting in injury to adopt improper tires, or operation of the ATV with improper of uneven tire pressure.

HOW TO AVOID THE HAZARD

Always adopt size and type of the tires specified for the ATV. Always maintain proper tire pressure as specified.

WARNING

POTENTIAL HAZARD: Operating the ATV with improper modifications.

WHAT CAN HAPPEN

Improper installation of accessories or modification of the ATV may cause changes in handling which could lead to an accident resulting in injury or death.

HOW TO AVOID THE HAZARD:

Never modify the ATV through improper installation or use of accessories. All parts and accessories added to the vehicle must be genuine our company or equivalent components designed for use on this ATV and should be installed and used according to approved instructions. See your local authorized dealer for more information.

WARNING

POTENTIAL HAZARD:

Overloading the ATV or carrying/towing cargo improperly.

WHAT CAN HAPPEN

Overloading and towing can cause changes in vehicle handling, which could lead to loss of control or an accident.

HOW TO AVOID THE HAZARD

Never exceed the stated load capacity for this ATV. Never carry passengers.

Cargo should be properly distributed and securely attached.

Reduce speed when carrying cargo or pulling a trailer. Allow a greater distance for braking.

Always follow the instructions in the owner's manual for carrying cargo or pulling a trailer.

WARNING

POTENTIAL HAZARD: Operating on frozen bodies of water.

Severe injury or death can happen if the ATV and/or the operator fall through the ice for loss of control

HOW TO AVOID THE HAZARD

Never operate the ATV on a frozen body of water.

CONTROLS

1	Main Switch	13	Shifting Lever
2	Speedometer	14	Brake Pedal
3	Front Light	15	Bumper
4	Left Handlebar	16	Front Fender
5	Right Handlebar	17	Tank Cap
6	Parking Lever	18	Front Shock Absorber
7	Rear Mirror	19	Seat
8	Footstand	20	Front Wheel
9	Rear Shock Absorber	21	Muffler
10	Rear Fender	22	Front Turning Light
11	Rear Wheel	23	Rear Turning Light
12	Engine	24	Reverse control switch clockwise

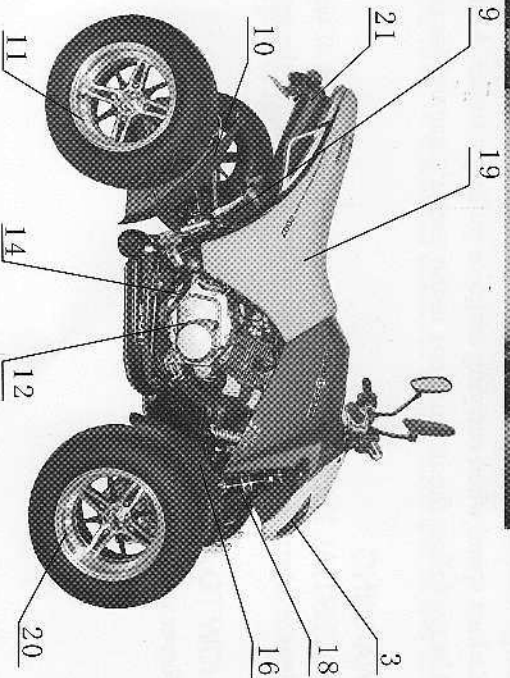
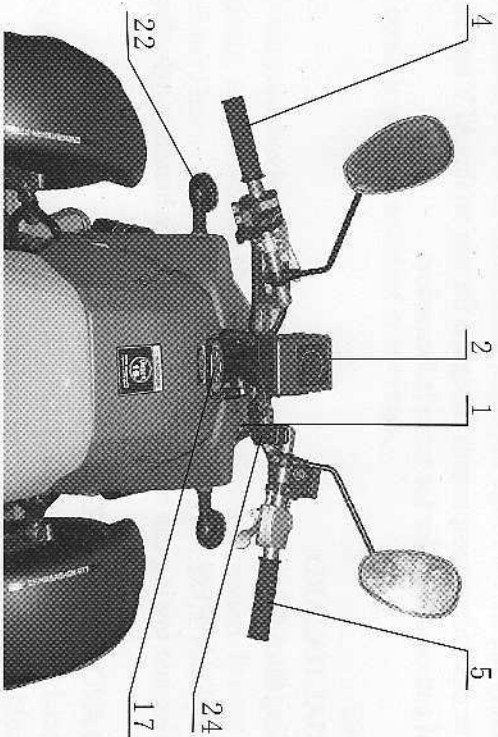
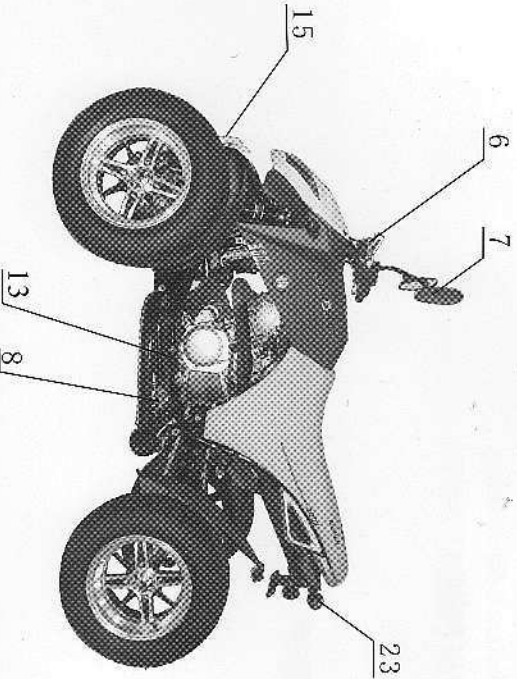

● Main Switch

Main switch is located on the right side of the vehicle.

There are ON "O" and OFF "X" on the switch.

Turn the key to X, main switch is turned off, the engine can not be started. The key can be removed.

Turn the key to O, the engine can be started, main switch is turned on, and the key can not be removed.

WARNING

Leaving the keys in the ignition can lead to unauthorized use of the vehicle

Resulting in serious injury or death. Always remove the ignition key when the vehicle is not in use. Remove the spare key and store it in a safe place. If both keys are lost, the ignition switch must be replaced.

Left Control Lever

Emergency Switch

Press the emergency switch to start the engine; press again to stop the engine. The purpose is to provide operator with a quick means of engine shutdown in case of an emergency.

Parking Brake Lever

Stop e parking brake.

Pull the park brake lever left to engage the brake.

Push the brake lever forward to release the rear wheel.

Main Switch

To start the engine, turn the stop switch and main switch on the O position. Squeeze the clutch lever by left hand, and step the brake pedal by right foot. Release the key when the engine starts.

1	Electric Start Button
2	Stop Switch
3	High and dipped Beam Switch
4	Horn Switch
5	Turning Light
6	Handle Rubber
7	Chock Switch
8	Parking Lever

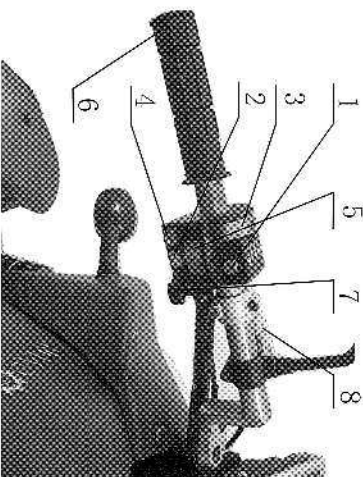
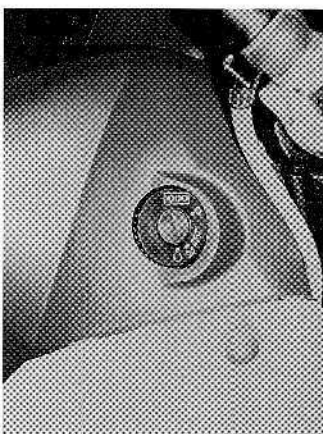

WARNING

Activate the starter for a maximum of 5 seconds. It only can be started again in 10 seconds when releasing the key.

Operating the ATV while the parking brake is engaged could result in an accident and serious injury or death. Always check to be sure the parking brake is disengaged before operating.

The parking brake may relax if left on for a long period of time. Always block the wheels to prevent rolling.

4. Accelerator controller

Throttle controls is located on the right side of handlebar.

Throttle Lever

Engine speed and vehicle movement are controlled by pressing the throttle lever .

The throttle lever is spring loaded. Engine speed returns to idle when the lever is released.

Speed Limit Screw:

Loosen the tightening nut, twist the adjust screw② to control the maximum speed. Twist the nut anticlockwise to increase the speed, and clockwise to decrease the speed. Tighten the tightening nut when adjust the speed.

WARNING

Operating an ATV with sticking or improperly operating throttle controls could cause an accident and lead to severe injury or death.

Never start or operate an ATV with a sticking or improperly operating throttle. Always contact your dealer for service if throttle problems arise.

Failure to check or maintain proper operation of the throttle system can result in an accident if the throttle lever sticks during operation.

Always check the lever for free movement and return before starting the engine. Also check occasionally during operation.

Parking Brake Lever

The auxiliary brake is applied by squeezing the brake lever toward the handlebar It only acts on

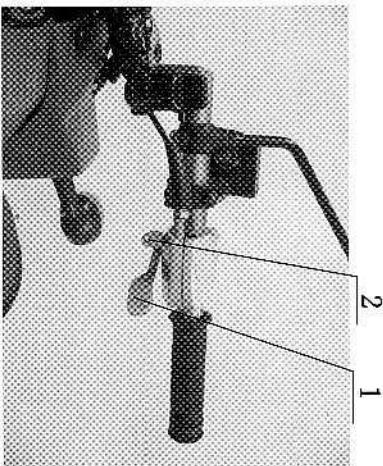

the front wheels

Your ATV has an auxiliary brake for added safety. It's located on the right side of handlebar and is operated by the right hand. The auxiliary brake serves as a backup to the main brake system if the main system becomes inoperative. If the rear wheels slide while using the auxiliary brake, reduce brake lever pressure to brake the rear wheels without skidding.

CAUTION:

The brake fluid in the master cylinder, which is located on the right handlebar, should be checked before each ride. The fluid level can be seen through an indicator window on the top of the master cylinder. This eye will appear dark when the fluid level is full. When fluid needs to be added, the eye will be clear.

When checking the fluid level, the ATV must be on level ground with the handlebars straight. If the fluid level is low add DOT 3 brake fluid only.

WARNING

Operating the ATV with a spongy brake lever or low brake fluid level can result in loss of braking, which could cause an accident.

Take caution when applying the auxiliary brake. Do not aggressively apply the auxiliary brake when going forward. The front wheels may skid and slide sideways, causing loss of control and serious injury or death.

Aggressively applying the auxiliary brake when driving down a hill may cause rear tip over, which could result in serious injury or death.

After opening a bottle of brake fluid, always discard any unused portion. Never store or use a partial bottle. Brake fluid is hygroscopic, meaning it rapidly absorbs moisture from the air. The moisture causes the boiling temperature of the brake fluid to drop, which can lead to early brake fade and the possibility of accident or severe injury.

Main Brake

The front and rear brakes are applied by pressing the brake pedal by right foot. The front and rear brakes are hydraulically activated disc type brakes that are activated by only one pedal. The method to check the main brake travel and auxiliary brake is the same.

Brake Fluid Level

Check the brake fluid level frequently for the brake system. The reservoir is located under the seat or near the auxiliary brake. Maintain the fluid level between the maximum and minimum marks.

CAUTION:

Always inspect the brake pedal. Lubricate the function parts frequently. The vehicle only can be driven when the broken or deformed brake pedal is maintained or replaced.

Always test brake pedal travel and master cylinder fluid level before riding.

When pressed, the pedal should feel firm.

Any sponginess would indicate a possible fluid leak or low master cylinder fluid level, which must be corrected before riding. Contact your dealer for proper diagnosis and repairs.

Always check disc brake fuel tube and disc brake pump leaks or broken before riding. Contact your dealer or authorized maintenance to replace the broken parts.

WARNING

Operating the ATV with low brake fluid level can result in loss of braking, which could cause an accident.

Operating the ATV with a spongy brake pedal can result in loss of braking, which could cause an accident.

Operating the ATV with leak disc brake tube or disc brake pump can result in no braking, which could cause an accident.

● **parking brake**

The parking brake is applied by pulling the parking brake lever. The parking brake lever is located on the left handlebar.

To set the parking brake, place the transmission in park, and stop the engine.

Pull the parking brake lever backward to the handlebar, now its in parking term.

To release the parking brake, push the lever back to it unlocked position.

CAUTION:

The parking brake may relax if left on for a long period of time. Always block the wheels to prevent rolling.

Always block the wheels on the downhill side of the ATV if leaving if parked on a hill. Another option is to park the ATV in a side hill position.

Never depend on the parking brake alone if the ATV is parked on a hill. Always block the wheels to prevent rolling.

WARNING

Operating the ATV while the parking brake is engaged could result in an accident and serious injury or death.

Fuel Valve, Fuel Filter

The fuel valve is located on the left side of tank bottom.

The switch up means it is in auxiliary oil condition. It is suggested.

The switch in the middle means the fuel valve is turned off. It is used for vehicle storage and when transporting.

The switch down means the fuel valve is in the normal operation or auxiliary oil condition.

The in-line fuel filter should be replaced by your dealer after every 100 hours of operation, or annually. Do not attempt to clean the fuel filter.

Gear Shifting

Gears are applied by pressing the gear shifting pedal. Gear shifting pedal is located on the left side of the vehicle.

Gear shifting mode:

R — N — 1 — 2 — 3 — 4

To shift into reverse gear, you must first apply the gear to N, then turn reverse control switch clockwise, meanwhile press forward the gear shifting pedal. To shift out reverse gear, tick backward only.

CAUTION

Shifting gears with the engine speed above idle or while the vehicle is moving could cause transmission damage.

Whenever the ATV is left unattended, always place the transmission in N and lock the parking brake and steering lock.

To extend belt life, use low forward gear in heavy pulling situations and when operating at less than seven miles per hour for extended periods of time.

● Instrument cluster

Instrument cluster (if there is) is the rider's information center.

The instrument cluster works while getting through the power of the instrument cluster. The information and function of the instrument cluster is as follows:

- ① Mode-change switch: changing the speedometer and speed into kilometer or miles with finger press .
- ② Engine Tachometer: timely display the information of the engine

- ③ Indication light
- ④ Mileage: display the mileage and total mileage.
- ⑤ High light: the high light illuminates with blue light.
- ⑥ Direction indicator: it illuminates with the switch on of direction indicator.
- ⑦ neutral indication
- ⑧ reverse indication
- ⑨ Oil level warning: you should check the gasoline and gas up when the light on.
- ⑩ emergency indication
- ⑪ Gears information: this is showing the gear works to indicate the rider.

Warning

Do not knock scratch the surface of instrument cluster, it will be damaged; do not refit or amend it, if something wrong with it, please contact the local dealer.

● carburetor

Caution:

Carburetor is a precision instrument; please do not dismantle it without professional knowledge.

Please check the intake valve of carburetor regularly, in order to avoid accident, please make sure if there is impurity.

If there is jam in carburetor, please ask for clearance in the professional maintenance shop or dealer.

Please check if there is oil leaking before riding. if there is, please repair before riding.

idle adjusting screw draining oil screw idle adjustment

Start the engine and warm the cylinder up to 95

Put the engine tachometer to the engine, or with a remoter.

Turning the idle adjusting screw with timing way can enlarge idle, Turning the screw with the betraying the timing way could reduce the idle, when the tachometer fluctuates between 1400r/min and 1600r/min, please stops.

Caution

The best proper way of engine idle adjustment must be taken under certain temperature.

Do not attempt to adjust the idle in other system; you can adjust it in professional maintenance shop or dealer shop.

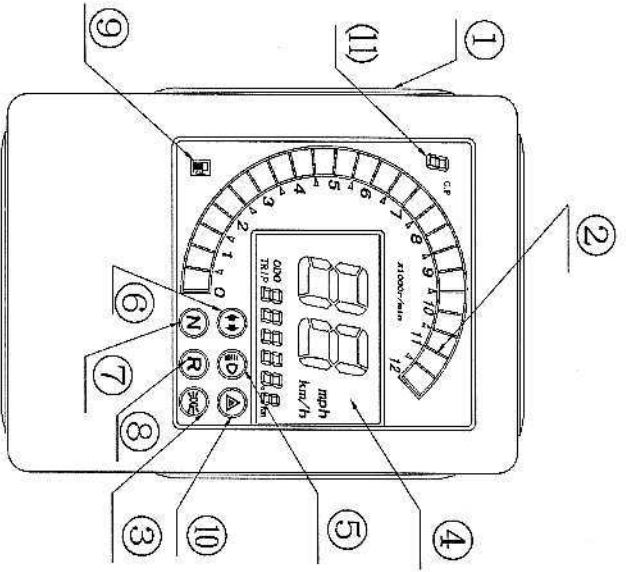

● battery

Caution

Electrolyte is poisonous, please do not dispose casually, and treat it according to the national or local environment regulations. Please take off the battery if the vehicle will be free for a long time, after full of charging, put it in dry circumstance.

If you want to keep the battery in the vehicle, you should disconnect the wires with the anode of the battery, and then disconnect the anode of the battery, do not have cathode or anode contacted the metal in order to avoid short circuit.

If the electrolytes touch your skin, you can wash it with water.

If the electrolyte touch your eyes, please wash it at once no less than 15 minutes and then ask for the doctor's help.

Electrolyte is poisonous, if you drink carelessly, you can drink much of water or milk and ask the doctor's help at once

Do not let the kids touch. Before putting the battery into box, please cut the cathode firstly and then the anode.

Warning

Keep far away of the spark, flame and cigarette, because battery can disperse poisonous gas. Please make sure there is ventilation if use the battery in a closed environment, or cause a explosion to dead.

The electrolyte is in battery, it could cause serious damage if touch the skin or eyes.

① anode



② cathode



● Engine cooling system

This engine is air and oil cooling, cooler is on the front of engine. If the oil cooler works smoothly Is related to the normal work and useful life of the engine, you should chose the related coolant in certain areas and environment.

Caution

Keep regularly check the oil cooler if there is dust in, if yes, please wash it at once.

Please check if the oil cooler fan works smoothly before riding, if the fan breaks, please replace it.

① Oil cooler ② fan

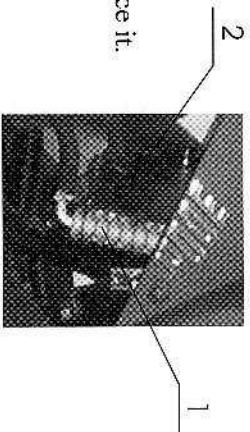
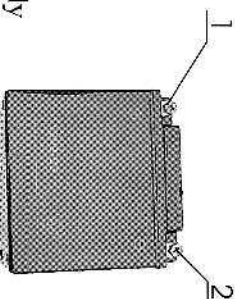

● Air filter

Clean the air filter every 30 days at least, if it works under the damp or dusty environment, please wash it more frequently. Cleaning process.

Remove air filter from frame of vehicle.

Drain the dust or sediment out of the intake valve by high-pressure of air current.

Fit the air filter by the way of negative direction of withdraw.

Caution

Do not wash the filter element with petrol or other impregnant, because the filter element is made of paper and other kind of petrol or the impregnant is explosive, or it would cause an explosion or fire.

Please do not start the engine without the air filter, or it could accelerate the abrasion.

Operation of your vehicle without a breather filter can cause engine damage. Always reinstall the breather filter after removing for service.

Please regularly check the intact of the air filter and maintenance or replace it if it is broken.

OPERATION

● Fuel Safety

Caution:

Please use unleaded gasoline no less than 92#.

Gasoline is highly flammable and explosive under certain conditions. Always with extreme caution whenever handling gasoline.

Always refuel with the engine stopped, and outdoors or in a well ventilated area.

Do not smoke or allow flames or sparks in or near the area where refueling is performed or where gasoline is stored. Do not overfill the tank.

Do not fill the tank neck.

If gasoline spills on your skin or clothing, wash it immediately with soap and water and change clothing.

Turn the fuel valve off whenever the ATV is stored or parked.

Warning

Never refuel in a close environment. It may cause injury to body by the steam volatilized by gasoline. No smoking and sparks are allowed during refueling. It may cause explosion or fire with people get injury or died.

The engine wears in and the lubricating oil matters needing attention

The break-in period for your new ATV is defined as the first 20 hours of operation, or the time it takes to use the first four full tanks of gasoline. No single action on your part is as important as following the procedures for a proper break-in. Careful treatment of a new engine will result in more efficient performance and longer life for the engine. Perform the following procedures carefully.

CAUTION

Overheat build-up during the first 5 hours of operation will damage close-fitted engine parts. Do not operate at full throttle or high speed for extended periods during the first 5 fours of use.

Using different brands or non-recommended oil may cause serious engine damage. We recommend the use of Premium synthetic Oil or another SAE15W/40-SF, or SF, SF, SC API certified SH oil. Never substitute or mix oil brands.

Check the oil reservoir level on the dipstick Add oil if necessary to maintain the level between the safe and add marks.

Drive slowly at first. Select an open area that allows room to familiarize yourself with vehicle operation and handling.

Perform regular checks on fluid levels, during the break-in period; change both the oil and the filter at 20 hours, 200 miles, or one month, whichever comes first?

● Pre-Ride Inspection

Warning

It would cause severe injury or accident of death if there is lack of proper inspection. Make sure the vehicle is under the good condition for riding.

Inspecting Items for pre-riding

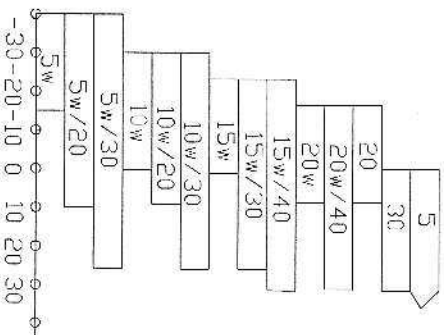

WARNING

If a proper inspection is not done before each use, severe injury or death could result. Always inspect the vehicle before each use to ensure it's in proper operating condition.

Item	Remark	Item	Remark
Brake system/lever travel	Ensure proper operation	Frame nuts, bolts, fasteners	Inspect, ensure each nuts and bolts tightness
Brake fluid	Ensure proper level(if applicable)	Fuel and oil	Ensure proper levels
Auxiliary brake	Ensure proper operation(if applicable)	Coolant level (if applicable)	Ensure proper level(if applicable)
Front suspension	Inspect, lubricate if necessary	Coolant hoses (if applicable)	Ensure operation
Rear suspension	Inspect, lubricate if necessary	Indicator lights/switch	Ensure operation
Steering	Ensure free operation	Engine stop switch	Ensure operation
Tires	Inspect condition and pressure	Air filter, pre-filter	Inspect, clean
Wheels rim /fasteners	Inspect, ensure fastener tightness	Air box sediment tube	Drain deposits whenever visible
Headlight	Check normal or not	Brake light/tail light	Check normal or not
Riding gear	Wear helmet, goggles, protective clothing		

● **Start the Engine**

Start the Cold Engine

Turn the ignition key to the ON position to engage the starter. Turn the fuel tank valve on.

Sit on the vehicle and place the transmission in PARK, pull the choke knob out until engine starts..

If the engine slows or stops, place the choke knob half way in to allow proper engine warm-up.

Make the engine RPM vary slightly with the throttle to aid in warm-up. When the engine idles smoothly, push the choke completely in.

CAUTION: The variable choke is fully on when the knob is pulled completely out. The choke is off when the knob is pushed completely in. The choke can be adjusted gradually, depending on how much choke is needed for starting. Be sure the choke is off during operation, as excess fuel washing in to the engine oil will speed up wearing on engine components.

Activate the starter for a maximum of five seconds, releasing the key when the vehicle starts. If the engine does not start, release the starter and wait five seconds. Activate the starter for another five seconds if necessary. Repeat this procedure until the engine starts.

WARNING

Run the vehicle immediately after starting could cause engine damage. Allow the engine to warm up for several minutes before operating the vehicle.

WARNING

Engine exhaust contains poisonous carbon monoxide and can cause loss of consciousness resulting in severe injury or death.

Starting a Warm Engine

Warm engine do not normally require the use of the choke. Using the choke can cause the spark plug to become wet fouled.

Park the vehicle on a level surface with the transmission in PARK. 2.Lock the parking brake, turn the fuel tank valve on, sit on the vehicle, and turn the engine stop switch to RUN.

If the engine has cooled to a point where it does not readily start, pull the choke continuously (knob pulled half way out) may be necessary.

If the engine is over-choked when heating, depress the throttle lever fully while cranking to aid in starting.

Release the throttle lever immediately after the engine starts. If the engine does not start and all conditions are favorable, change the spark plug and try again.

If the ATV is used year-round, check the oil level frequently. A rising oil level could indicate the accumulation of contaminants such as water or excess fuel on the bottom of the oil tank. Water on the bottom of the accumulation increases as outside temperature decreases.

Wheel installation

Proper tire pressure can make the riding more comfortable and prolong the using time. Often check the tire pressure and adjust it when necessary.

pressure (Kpa)	Front wheel: 100	Rear wheel: 100
tire size	215/50-12	215/50-12

Caution

Check the tire pressure before riding, and make sure if there is no cut, nail or other stiff things on the tire.

Check if the rim is sunken, transformed or needing replaced.

Always ensure that all nuts are tighten before driving.

Always replace tires when tread depth is worn to 1/8" (.3 cm) or less.

Warning

Do not repair the broken tire, or the balance and stability would be influenced and it may lead overturn.

Less of tire air can affect the steering stability and cause the hidden trouble, e.g. if the tire can not hold the ground tightly and cause the rim out of tire, even it is possible to loss control and cause death.

Overcharging of air also can cause danger, because it affects the friction and operation.

Driving Safely

Hauling Cargo

Your ATV has been designed to carry or tow a certain amount of load. Always read and understand the load distribution warning labels on the vehicle, and never exceed the weight capacities outlined in the specifications section of the owner's manual and on the safety decals.

Cargo weight should be evenly distributed (1/3 on the front rack and 2/3 on the rear rack) and mounted as low as possible. When operating over rough or hilly terrain, reduce speed and cargo weight to maintain stable driving conditions. Do not obstruct the headlight beam with cargo.

Use low forward gear when hauling or towing heavy cargo to extend belt life.

Cargo weight distribution should be 1/3 on the front rack and 2/3 on the rear rack. When operating over rough or hilly terrain, reduce speed and cargo to maintain stable driving conditions. Carrying loads on one rack only increases the possibility of vehicle overturn. Carrying loads high on the racks raises the center of gravity of the vehicle and creates a less stable operating condition.

SECURE ALL LOADS BEFORE OPERATING.

Unsecured loads can create unstable operating conditions, which could result in loss of control of the vehicle.

OPERATE ONLY WITH STABLE AND SAFELY ARRANGED LOADS.

When handling off-centered loads that cannot be centered, securely fasten the load and operate with extra caution. Always attach the tow load to the hitch point designated for your vehicle.

HEAVY LOADS CAN CAUSE BRAKING AND CONTROL PROBLEMS.

Use extreme caution when applying brakes with a loaded vehicle. Avoid terrain or situations that may require backing downhill.

USE EXTREME CAUTION

when operating with loads that extend over the rack sides. Stability and maneuverability may be adversely affected, causing the vehicle to overturn.

Do not block the front headlight beam when carrying loads on the front rack.

Do not travel faster than the recommended speeds.

Vehicle should never exceed 10 mph (16kph) while towing a load on a level grass surface. Vehicle speed should never exceed 5 mph (8kph) when towing loads in rough terrain, while cornering, or while ascending or descending a hill.

Warning!

Improper loading on your ATV can make you lose the control of steering or the steady of break, and lead to injury or death. Never carry cargo when no rear carrier or box are equipped to drive, otherwise accident will happen, even cause injury or death to rider.

Making Turns

Note:

Your ATV is equipped with a solid rear axle, which drives both rear wheels equally at all times. The wheel on the outside of the turn travels a greater distance than the inside wheel when turning, and the inside tire slips traction slightly. To turn, steer in the direction of the turn, leaning your upper body to the inside of the turn while supporting your weight on the outer footpad. This technique alters the balance of traction between the rear wheels, allowing the turn to be made smoothly. The same leaning technique should be used for turning in reverse.

Practice making turns at slow speeds before attempting to turn at faster speeds.

WARNING

Turning at sharp angles or at excessive speeds can result in vehicle overturn and lead to serious injury or death. Avoid turning at sharp angles. Never turn at high speeds.

Driving on slippery surfaces

Note:

Whenever riding on slippery surfaces such as wet trails or loose gravel, or during freezing weather, follow these precautions:

1. Slow down when entering slippery areas.
2. Maintain a high level of alertness, reading the trail and avoiding quick, sharp turns, which can cause skids.
3. Correct a skid by turning the handlebars in the direction of the skid and shifting you weight forward.
4. If you use AWD (if there is) when rear wheels still work, it may destroy the drive axle. Do not use AWD until rear wheels stopped or lose of traction.

Warning:

Failure to exercise care when operation on slippery surfaces can result in loss of tire traction and cause loss of control, accident, and serious injury or death.

Never apply the brakes during a skid. Do not operate on excessively slippery surfaces. Always reduce speed and use additional caution, especially when downshifting.

Driving uphill

Note:

Whenever traveling uphill, following these precautions:

1. Always travel straight uphill.
2. Avoid steep hills(20 maximum)
3. Keep both feet on the footplates and shift your weight forward.
4. Proceed at a steady rate of speed and throttle opening.
5. Be alert and prepared to take emergency action. This may include quick dismounting of vehicle.

Warning:

Braking and handling are greatly affected when operating in hilly terrain. Improper procedure could cause loss of control or overturn and result in serious injury or death.

It may cause loss of control or overturn when operating on hill more than 20° .

Use extreme caution when operating on hills, and follow all procedures outlined in the owner's manual.

Driving across hills

Note:

Avoid crossing the side of a hill when possible. Follow proper procedures as outlined in the owner's manual.

If you enter into a situation where side hilling is unavoidable:

1. Slow down.
2. Lean into the hill, transferring your upper body weight toward the hill while keeping your feet on the footplates.
3. Steer slightly into the hill to maintain vehicle direction.
4. If the vehicle begins to tip, quickly turn the front wheels downhill, if possible, or dismount on the uphill side immediately!

Warning!

Improperly crossing hills or turning on hills can result in loss of control or vehicle overturn, resulting in severe injury or death

Driving downhill

Note:

Whenever descending a hill, follow these precautions:

1. Proceed directly downhill.
2. Transfer your weight to the rear of the vehicle.
3. Slow down.
4. Shift to the lowest gear possible while maintaining a safe speed.
5. Apply the foot brake slightly to aid in slowing.

Warning:

Excessive speed can cause loss of control and lead to serious injury or death. Always operate slowly when traveling downhill.

● **Turning around on a hill**

Avoid climbing steep hills (20° maximum)

Use extreme caution when operating on hills, and follow proper operation procedures outlined in the owner's manual. If the vehicle stalls while climbing a hill, never back it down the hill!

One maneuver that can be used when it's necessary to turn around while climbing a hill is the K-turn:

Stop ATV, lock the parking brake, and keep your body weight uphill.

Shut off the engine leaving the transmission in gear.

Dismount on the uphill side of the vehicle or on the left side if the vehicle is pointing straight uphill.

Keep ATV uphill, and turn the handlebar to full left.

With the front brakes applied, pull in the clutch lever. Use the brakes to slowly allow the vehicle to roll around to your right until it's pointing across the hill or slightly downward.

Lock the parking brake, and restart from the direction of uphill; keep your body weight uphill.

Restart the engine with the working transmission system.

Release the parking brake and control the speed with hand brake until ATV reach smooth place.

WARNING:

Improper hill climbing procedures could cause loss of control or overturn and result in serious injury or death.

● **Driving through water**

Note:

Your ATV can operate through water with a maximum recommended depth equal to the level of the foottag. Follow these procedures when operating through water:

1. Check water depths and current before crossing.
2. Choose a crossing road where both banks have gradual inclines.
3. Proceed slowly, avoiding rocks and obstacles if possible.
4. After crossing, dry the brakes by applying light pressure to the lever until braking action is normal.
5. Avoid operating the vehicle through deep or fast-flowing water. If you cannot avoid water that exceeds the recommended maximum depth, go slowly, balance your weight carefully, avoid sudden movements, and maintain a slow and steady forward motion. Do not make sudden turns or stop, and do not make sudden throttle changes.
6. If your vehicle becomes immersed or is operated in water that exceeds the foot peg level, take it to your dealer for service before start the engine.

Warning!

Major engine damage can result if the vehicle is not thoroughly inspected after operation in water.

Driving over obstacles

Note:

Be alert!

Look ahead and learn to read the terrain you're traveling on. Be constantly alert for hazards such as logs, rocks and low hanging branches

Warning!

Severe injury or death can result if your vehicle comes in contact with a hidden obstacle. Not all obstacles are immediately visible. Travel with caution in unfamiliar terrain.

Driving in Reverse

Note:

Follow these precautions when operating in reverse:

1. Avoid move downhill in reverse gear.
2. Move back slowly. Apply the brakes lightly for stopping.

avoid turning at sharp angles; never open the throttle suddenly while backing

Warning!

Failure to use caution when operating in reverse can result in serious injury or death. Before shifting into reverse, always check for obstacles or people behind the vehicle.

parking on slope

Avoid parking on an slope if possible. If it's unavoidable, follow these precautions:

Turn the engine off place the transmission in first gear, lock the parking brake, always block the rear wheels on the down hill side. See illustration. Turn the fuel valve off. parking on slope

Avoid parking on an slope if possible. If it's unavoidable, follow these precautions:

Turn the engine off place the transmission in first gear, lock the parking brake, always block the rear wheels on the down hill side. See illustration. Turn the fuel valve off.

Periodic Maintenance Chart

Careful periodic maintenance will help keep your vehicle in the safest, most reliable condition. Inspection, adjustment and lubrication of important components are explained in the chart of maintenance and lubrication. Inspect, clear, lubricate, adjust and replace parts as necessary. When inspection reveals the need for replacement parts, use our genuine parts available from your dealer.

Vehicles subjected to severe use must be inspected and serviced more frequently.

Item	Maintenance Period		Remarks	Item	Maintenance Period		Remarks
	Date: Month	Miles: Km			Date: Month	Miles: Km	
Steering	—	—	Check pre-ride	General lubrication	3	800	Lubricate all fittings
Front suspension	—	—	Check pre-ride	Carburetor	6	1000	Inspect periodically
Rear suspension	—	—	Check pre-ride	Throttle	6	1000	Inspect periodically
Braking pedal	—	—	Check pre-ride	Engine oil change	6	1000	Replace periodically
Brake system	—	—	Check pre-ride	Radiator	12	2000	Inspect, clean
wheels nuts	—	—	Check pre-ride	Muffler	12	2000	inspect
Engine and frame connection	—	—	Check pre-ride	Cooling hose	6	1000	Inspect leaking
Air filter element	3	600	Check pre-ride	chain	3	600	adjust, lubricate
Light	—	—	Check pre-ride	spark plug	1	200	Inspect, clean
oil tube	—	—	Check pre-ride	tire	1	200	Inspect
Brake pad	1	200	Inspect periodically	meter	—	—	Check pre-ride
Battery	1	300	Inspect periodically	circuit	—	—	Check pre-ride

Maintenance and Lubrication

● Lubrication Recommendations

4 All Season synthetic engine oil of our company has been specially formulated for use in 4-cycle engines. It's a fully synthetic, high performance, multi-viscosity oil designed to provide the ultimate in lubrication performance and protection. You also can use the lubrication oil with the SH certificate under the 5W-15W/40, though it is recommended only for the use in engine.

CAUTION!

Mixing brands or using a non-recommended oil may cause serious engine damage.

● Engine oil Level

The dipstick(1) is located on the right side of the engine

Start the engine and let it idle for 20 to 30 seconds

Stop the engine and remove the dipstick. Wipe it dry with a clean cloth

Reinstall the dipstick completely. The dipstick must be screwed completely to keep the angle and depth of the stick consistent.

Remove the dipstick and check the oil level. Maintain the oil level between the full and add marks. Do not overfill

Caution

If the ATV is used year-round, check the oil level frequently. A rising oil level could indicate the accumulation of contaminants such as water or excess fuel in the bottom of the oil tank. Please replace immediately if the oil level is under the limits.

oil change

Position the vehicle on a level surface. Clean the area around the oil tank and crankcase

Run the engine for two to three minutes until warm, then stop the engine.

Place a drain pan beneath the oil tank and remove the drain plug, allow the oil to drain completely

Reinstall the drain plug and infuse 1 L of kerosene from dipstick.

Run the engine for 20 to 30 seconds, then turn off and drain.

Add fresh standard lubrication oil about 1.5L

WARNING!

Please make sure the drain plug be tightened after the change of oil
It will cause a great damage on the engine when you start engine without gasoline.

The lubrication of transmission chain

Position the ATV on a level surface, start the engine and let it idle

Clean the transmission chain

Daub the transmission chain and wheels with cloth or brush conglutinated by the specified lubrication oil.

CAUTION

Please replace the chain and sprocket wheel at the same time when they have been worn deeply.

WARNING

Short of lubrication oil may accelerate the abrasion between chain and sprocket and then separated, it may cause loss of control and result in severe injury or death.

The chain lack of the lubrication will accelerate the abrasion between chain and chain wheels, cause severe injury and death

Cooling System Maintenance.

The engine cooling system plays an important role in the cooling system.

The model of vehicle is liquid-cooling and air cooling.

CAUTION:

Frequently inspect the surface of the oil-cooler, please clean with water if there is dust, but not with too high-pressure water. Because it may make the radiator out of shape

Check the fans of the oil-cooled before operating, please replace if needed.

The insufficiency of the machine oil will cause the adverse performance of the radiator, thus frequently inspect and complement when need.

WARNING.

The broken radiator and connecting hose may cause a great damage on the engine, please inspect pre-ride.

● **Lubrication Recommendations**

4 All Season synthetic engine oil of our company has been specially formulated for use in 4-cycle engines

It's a fully synthetic, high performance, multi-viscosity oil designed to provide the ultimate in lubrication performance and protection. You also can use the lubrication oil with the SH certificate under the 5W-15W/40, though it is recommended only for the use in engine.

CAUTION!

Mixing brands or using a non-recommended oil may cause serious engine damage.

● **Engine oil Level**

The dipstick(1) is located on the right side of the engine

Start the engine and let it idle for 20 to 30 seconds

Stop the engine and remove the dipstick. Wipe it dry with a clean cloth

Reinstall the dipstick completely. The dipstick must be screwed completely to keep the angle and depth of the stick consistent.

Remove the dipstick and check the oil level. Maintain the oil level between the full and add marks. Do not overfill

Caution

If the ATV is used year-round, check the oil level frequently. A rising oil level could indicate the accumulation of contaminants such as water or excess fuel in the bottom of the oil tank. Please replace immediately if the oil level is under the limits.

oil change

Position the vehicle on a level surface. Clean the area around the oil tank and crankcase

Run the engine for two to three minutes until warm, then stop the engine.

Place a drain pan beneath the oil tank and remove the drain plug, allow the oil to drain completely

Reinstall the drain plug and infuse 1 L of kerosene from dipstick.

Run the engine for 20 to 30 seconds, then turn off and drain.

Add fresh standard lubrication oil about 1.5L

WARNING!

Please make sure the drain plug be tightened after the change of oil

It will cause a great damage on the engine when you start engine without gasoline.

The lubrication of transmission chain

Position the ATV on a level surface, start the engine and let it idle

Clean the transmission chain

Daub the transmission chain and wheels with cloth or brush conglutinated by the specified lubrication oil.

CAUTION

Please replace the chain and sprocket wheel at the same time when they have been worn deeply.

WARNING

Short of lubrication oil may accelerate the abrasion between chain and sprocket and then separated, it may cause loss of control and result in severe injury or death.

The chain lack of the lubrication will accelerate the abrasion between chain and chain wheels, cause severe injury and death

Cooling System Maintenance.

The engine cooling system plays an important role in the cooling system.

The model of vehicle is liquid-cooling and air cooling.

CAUTION:

Frequently inspect the surface of the oil-cooler, please clean with water if there is dust, but not with too high-pressure water. Because it may make the radiator out of shape

Check the fans of the oil-cooled before operating, please replace if needed.

The insufficiency of the machine oil will cause the adverse performance of the radiator, thus frequently inspect and complement when need.

WARNING.

The broken radiator and connecting hose may cause a great damage on the engine, please inspect pre-ride.

The maintenance of braking system.

The braking system plays a great role in the safety of riding, thus its maintenance is very important. The front and rear brakes are hydraulic disc brakes, and activated by the foot brake pedal. Both brakes are self-adjusting. Some checking processes for sound braking condition are listed in the following.

CAUTION:

Never store or use any brake fluid, it is hygroscopic and will immediately absorb the aquosity in the air, the moisture will make the brake fluid boiling and dripping, cause the failure of the brake system. Desert a part of the useless after opening a bottle of brake fluid.

Check to see there is no leakage from the system

Check the overuse of the brake.

Check the braking pads for wear, immediately change if need

Replace the brake disc when it has been worn to 3mm

Check the brake main cylinder for proper oil level,

The replacement of the braking pads should be performed by your dealer.

WARNING!

One overcharged oil-tank may have the break overloaded or automatic locked, this would cause a serious injure and death. Please keep the breaking-oil on the proposal lever and do not overflow.

Severe injury or death can result from riding ATV under the condition of without brake, or inferior brake performance.

THE MAINTENANCE OF F&R WHEELS

CAUTION:

Keep proper tire pressure as described on the ATV decal and in the owner's manual. Make sure the wheels are installed properly

Always replace tires when tread depth is worn to 3mm.

The F&R wheel nuts is the key parts in the vehicle, please do not dismantle or install yourself

Tire pressure should be check before you ride while the tires are cold, check the tires for cuts, embedded nails, or other sharp objects.

Check the rims for dents or deformation.

Do not attempt to patch a damaged tire or inner tube, otherwise wheel balance and tyre reliability may be impaired

Improper tire inflation will cause abnormal tread wear and create a safety hazard.

● Battery

CAUTION:

When installing a new battery, make sure it's fully charged prior to its initial use. Using a new battery that has not been fully charged can damage the battery and result in a shorter life. It can also hinder vehicle performance.

When the vehicle is placed in storage for three months or more, the battery should be removed and stored in dark, cool, dry place. Test and recharge the battery monthly and before using again.

Use a voltmeter or multimeter to measure DC voltage. Fully charged battery will register 12.8 V or higher.

If the voltage is less than 12.8volts, recharge it.

Never plain tap water to a battery, it can ruin a battery because of the minerals in it. Only fill distilled water as plain water. Please follow the specification below when use DC charging.

Note: Always verify battery condition before and 1-2 hours after charging.

Warning!

An overheated battery could explode, causing severe injury or death. Always watch charging times carefully.

Stop charging if the battery becomes very warm to the touch. Allow it to cool before resuming charging.

Improperly connecting or disconnecting battery cables can result in an explosion and cause serious injury or death. When removing a battery, always disconnect the negative (black) cable first. When reinstalling the battery, always connect the negative cable last.

State of Charge	Voltage	Action	Charge time
100%	12.813.0 v	None, check at 3 months from date of manufacture	No required
75%--100%	12.512.8 v	May need slight charge, if no charge given, check in 3 months	3-6 hours
50%--75%	12.012.5 v	Needs charge	5-11 hours
25%--50%	11.512.0 v	Needs charge	At least 13 hours, verify state of charge
0%--25%	11.5 volts or less	Needs charge	At least 20 hours

Cleaning, Storage and Transportation of the vehicle.

Cleaning

Keep your vehicle clean will not only improve its appearance but also it can also extend the life of various components.

The best and safest way to clean the vehicle is with a garden hose and a pail of mild soap and water. Use a professional -type washing cloth, cleaning the upper body first and the lower parts last. Rinse with clean water frequently. Dry surfaces with a chamois to prevent water spots.

If a high pressure water system is used for cleaning (not recommended), exercise extreme caution. Avoid directing the water stream at the following items: Transmission seals, Cab and body panels, Brakes and Labels and Decals.

CAUTION:

Grease all zerk fitting immediately after washing. Allow the engine to run for a while to evaporate any water that may have entered the engine or exhaust system.

Avoid the use of automotive products, some of which can scratch the finish of your vehicle.

WARNING:

Certain products, including insect repellents and chemicals, will damage plastic surface. Do not allow these types of products to contact the vehicle.

STORAGE

When the vehicle will be in long period of storage, do the procedure as following.

Rinse with clean water, towel surfaces to prevent water spot and recline it for several hours.

Drain out all gasoline in the fuel tank, and daub antirust on the interior of fuel tank.

Unscrew the oil nail and drain out of gasoline in the carburetor, and then screw the oil nail tightly.

Taking of the spark plug, infusing about 10ml engine oil in the cylinder, electrically start the engine, the engine oil will come into the piston ring and form a protective membrane in the cylinder.

Inspect and clean or replace the pre-cleaner and air filter, Clean the air box and drain the sediment tube.

Inspect the following fluid level and change if necessary: front and rear gear cases; transmission and brake fluid (change every two years or as required if fluid look dark or contaminated).

Inspect all cables and lubricate. Follow lubrication guidelines in the Maintenance Section of the service or owner's manual to completely grease and lubricate the entire vehicle with Premium All Season Grease.

The battery should be removed, stored out of the sun in a cool, dry place alone. When removing the battery, always disconnect the negative (black) cable first.

Apply anti-rust lubricating oil to the drive chain.

Apply lubricating oil to front suspension, rear axle and rear fork.

Routinely and liberally apply a weather resistant wax to each polished chrome part.

Set the tire pressure and safely support the ATV with the tires 30-40mm off the ground. Be sure the storage area is well ventilated, and cover the machine with a genuine ATV cover.

NOTE:

Do not use plastic or coated material. They do not allow enough ventilation to prevent condensation, and may promote corrosion and oxidation.

Make sure clean the fuel tank with gasoline and refill the fresh gasoline while restoring the vehicle.

Please make sure recharge the battery before installing the battery.

Check lubrication of all movement parts when restoring the vehicle. Lubricate if necessary.

When you start to use vehicle after a long period of storage, eliminate any lubrication remaining in the engine, then to lubricate again after cleaning engine with kerosene.

Transporting the ATV

Follow these procedures when transporting the vehicle.

Turn off the engine and remove the key to prevent loss during transporting.

Place the transmission in PARK and lock the park brake.

Turn the fuel valve off and be sure the fuel cap, oil cap and seat are installed securely.

Always tie the frame of the ATV to the transporting unit securely with suitable straps or rope. Do not attach the strap to the front swing-arms bolt pockets.

● TROUBLE SHOOTING

See your dealer, or go to a professional repair shop when your vehicle is out of work. Also you may solve some simple problems yourself according to the solution below.

Possible Cause	Solution
Weak spark from spark plugs	Inspect, clean and /or replace spark plugs
incorrect spark plugs gap or heat range	Set gap to specs or replace plugs
Old or non-recommended fuel	Replace with new fuel
Incorrectly installed spark plugs wires	See your dealer or go to a repair shop
incorrect ignition timing	See your dealer or go to a repair shop
Mechanical failure	See your dealer or go to a repair shop
Engine runs irregularly, stalls or misfires	Solution
Worn or defective spark plug wires	replace spark plugs
Inspect, clean and/or replace spark plugs	Check all connections and tighten
Water present in fuel	Replace with new fuel
Low battery voltage	Recharge battery to 12.5 VDC
Kinked or plugged fuel vent line	Inspect and replace
Incorrect fuel	Replace with recommended fuel
Clogged air filter	Inspect and clean or replace
Reverse speed limiter malfunction	See your dealer or go to a repair shop
Electronic throttle control malfunction	See your dealer or go to a repair shop
Overuse of choke	Inspect and clean spark plugs
Incorrect fuel with incorrect octane rating	Replace with recommended fuel

Engine

Backfires

Loses Power

Possible Cause	Solution
Out of fuel	Refuel
Kinked or plugged fuel vent line	Inspect, clean and replace
Water present in fuel	Replace with new fuel
Overuse of choke	Inspect, clean and /or replace spark plugs
Fouled or defective spark plugs	Inspect, clean and/or replace spark plugs
Incorrect spark plug gap	Set gap to spark plugs
Clogged air filter	Inspect and clean
Kinked or plugged fuel vent line	Inspect, clean and replace
engineer malfunction	See your dealer or go to a repair shop
worn of electric apparatus	Replace
electrocircuit failure	See your dealer or go to a repair shop
Overheated engine	Clean radiator screen and core, Clean engine exterior, and operate in right way

Engine Stops or

Warning!

A hot exhaust system and engine can cause serious burns, please wait for engineer and exhaust system cooling to room temperature for inspection and repair.

Use a garden hose to flush any debris from the radiator fins.

NOTE: high pressure washers can deform the radiator fins and reduce cooling efficiency.

Specifications

Dimensions		Electronical Parameters	
Overall length	1770 mm	Battery	12v 14Ah
Overall width	1220 mm	Headlight	12v 35w/35w
Overall height	1020 mm	Indication light	12v 3w
Axle base	1250 mm	Turning light	12v 10w X 4
Mini ground clearance	130 mm	Break/tailor light	12v 21w/5w
Weight specification		Instrument cluster light	12v 3w
Gross vehicle weight	233 kg	Neutral indicator	12v 12v
Max. Gross weight	226 kg	Fuse	15A
Immobilie parameter		Structure	
Minimum turning Diameter	6 m	Engine type/model	single cylinders, oil-cooling, four stroke.
Fuel capacity	8 l		274ml
Lubrication capacity	1.5 l	Cylinder capacity	75mm X 62mm
Front tire size	215/50-12	Cylinder diameter x journey	8.67 : 1
Rear tire size	215/50-12	Compression proportion	CDI
Front tire air pressure	100 kpa	Ignition mode	12.5kw(7000r/min)
Rear tire air pressure	100 kpa	Rated power	19.7n.m(5500)r/min
Transmission	chain drive	Max. Torque	pressure splash
Absorber	spring hydraulic absorber	Lubrication	electric/ hand recoil
Primary engine transmission rate	3.318	Starting mode	automatic clutch
Final transmission rate	3	Lutch mode	centrifugal-wet multiple piece
Engine gearshift transmission rate	first gear 2.833		SE 15W/40 oil
	second gear 1.706	Engine oil	
	reverse gear 3.467		
	third gear 1.19		
	fourth gear 0.957		
Fuel specification	92#gas		
Fuel			
Parking	front: disc brake rear disc brake		

Electrical principle diagram

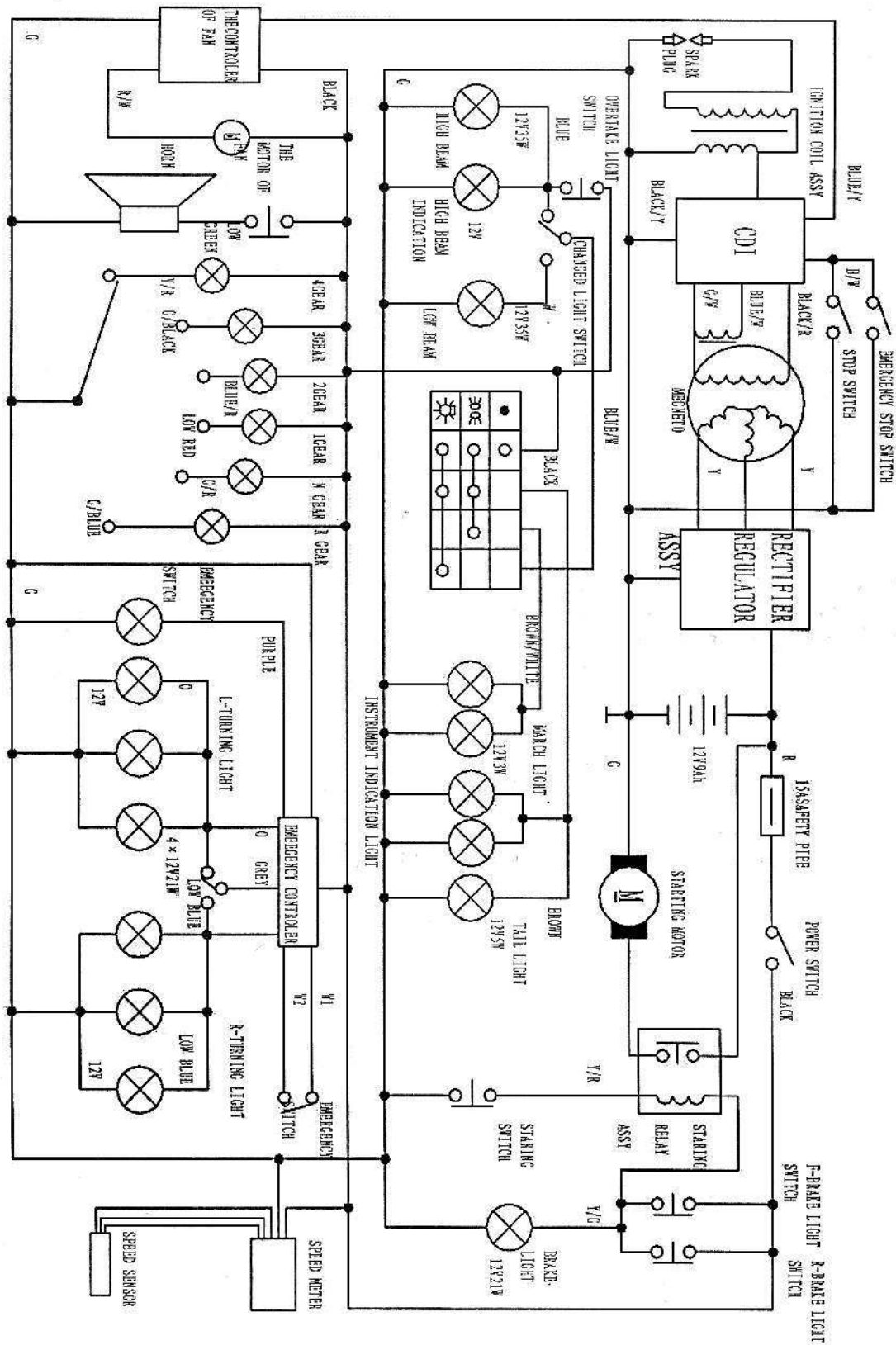

FRAME ASSEMBLY (1)

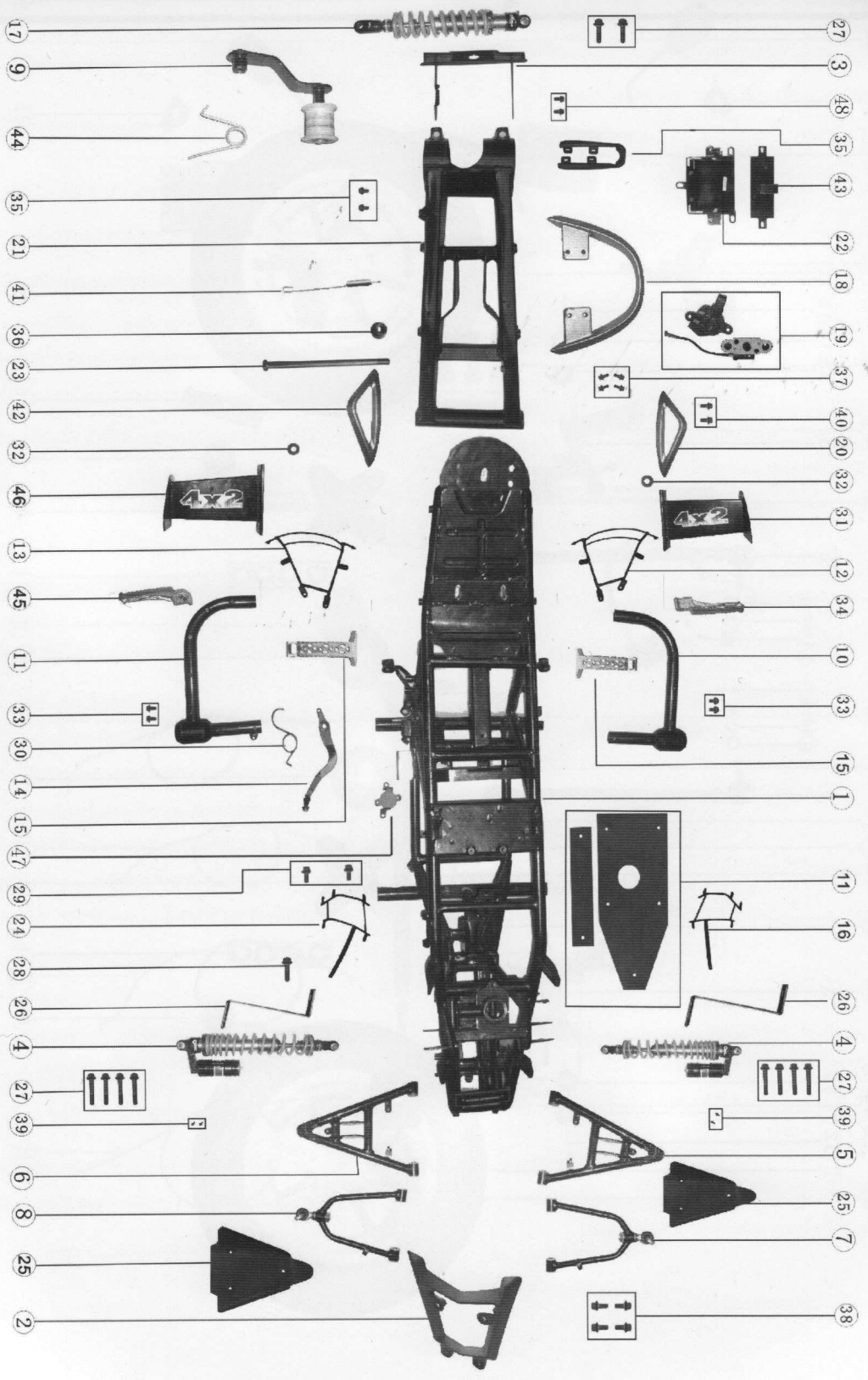

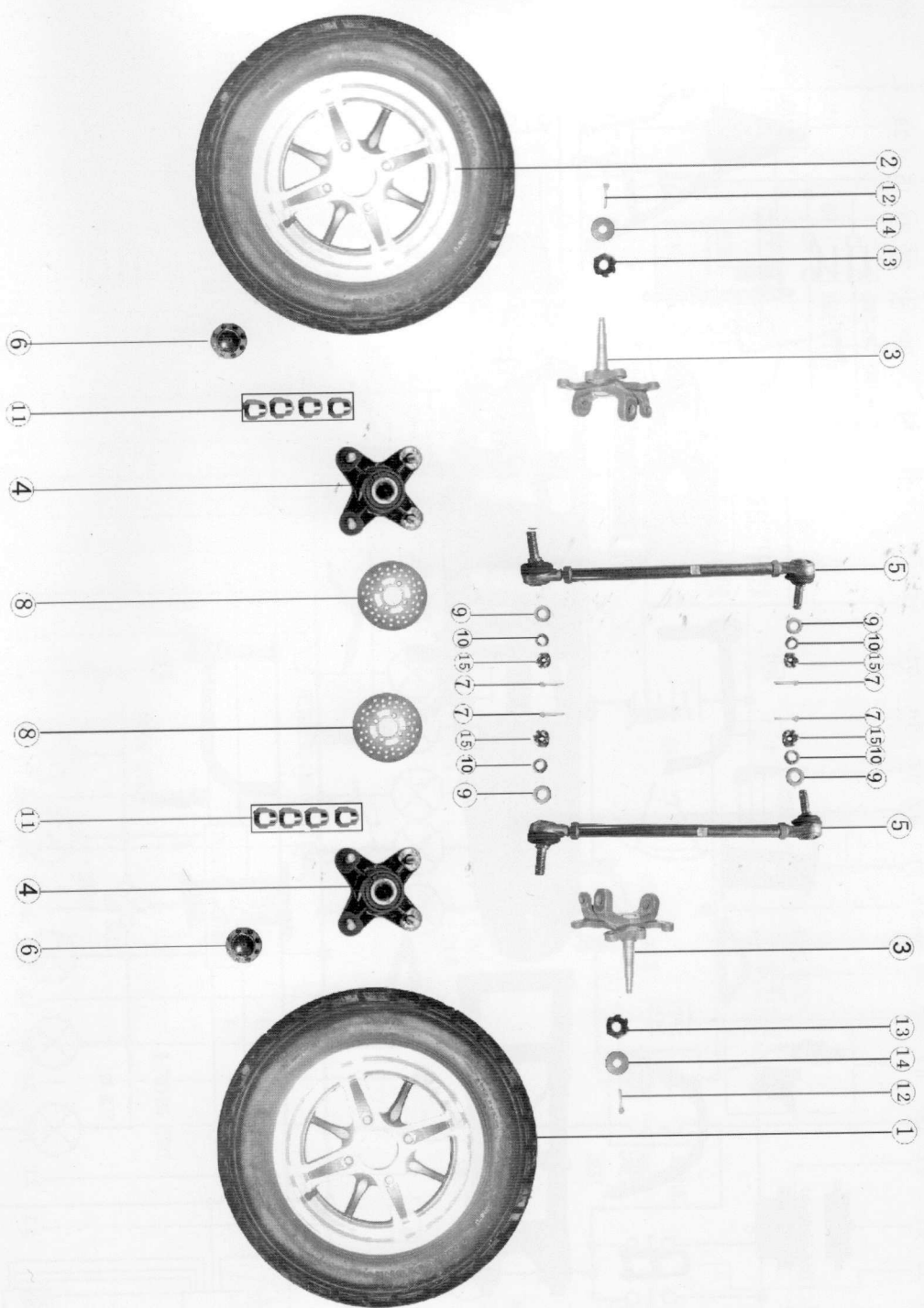

FRONT WHEEL ASSEMBLY (2)

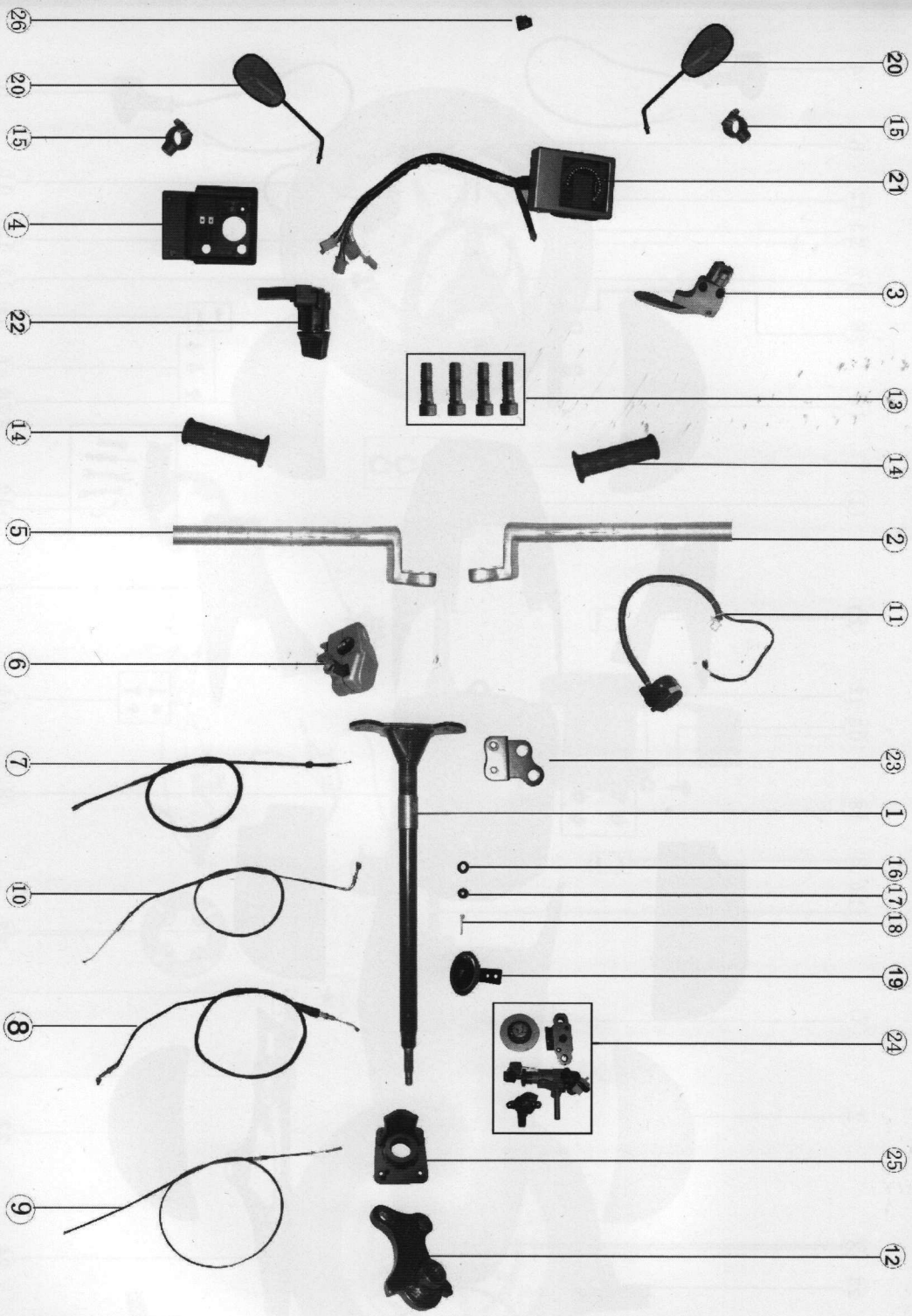

FRONT FORK ASSEMBLY (6)

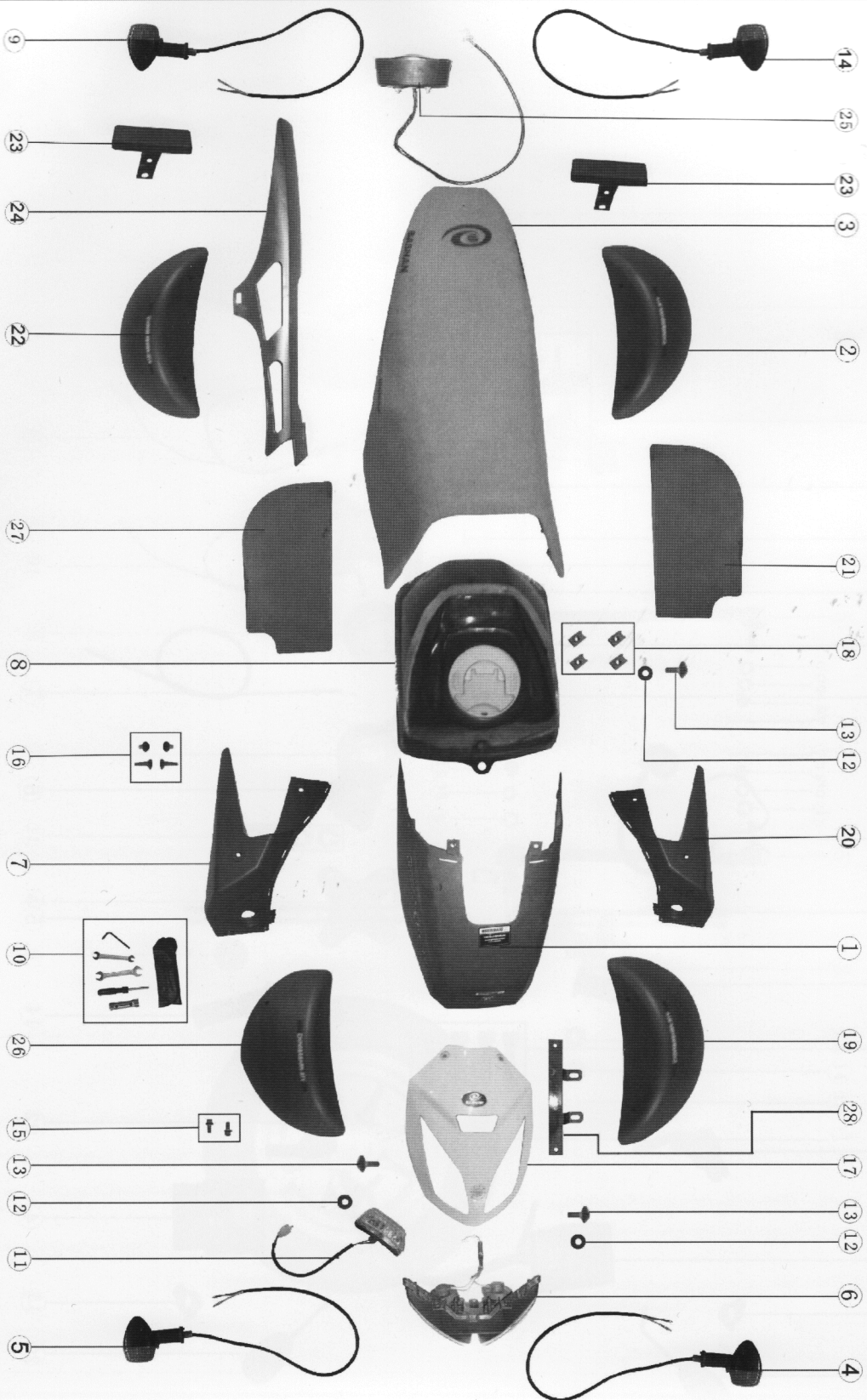

COVERING PARTS ASSEMBLY (3)

REAR WHEEL ASSEMBLY (5)

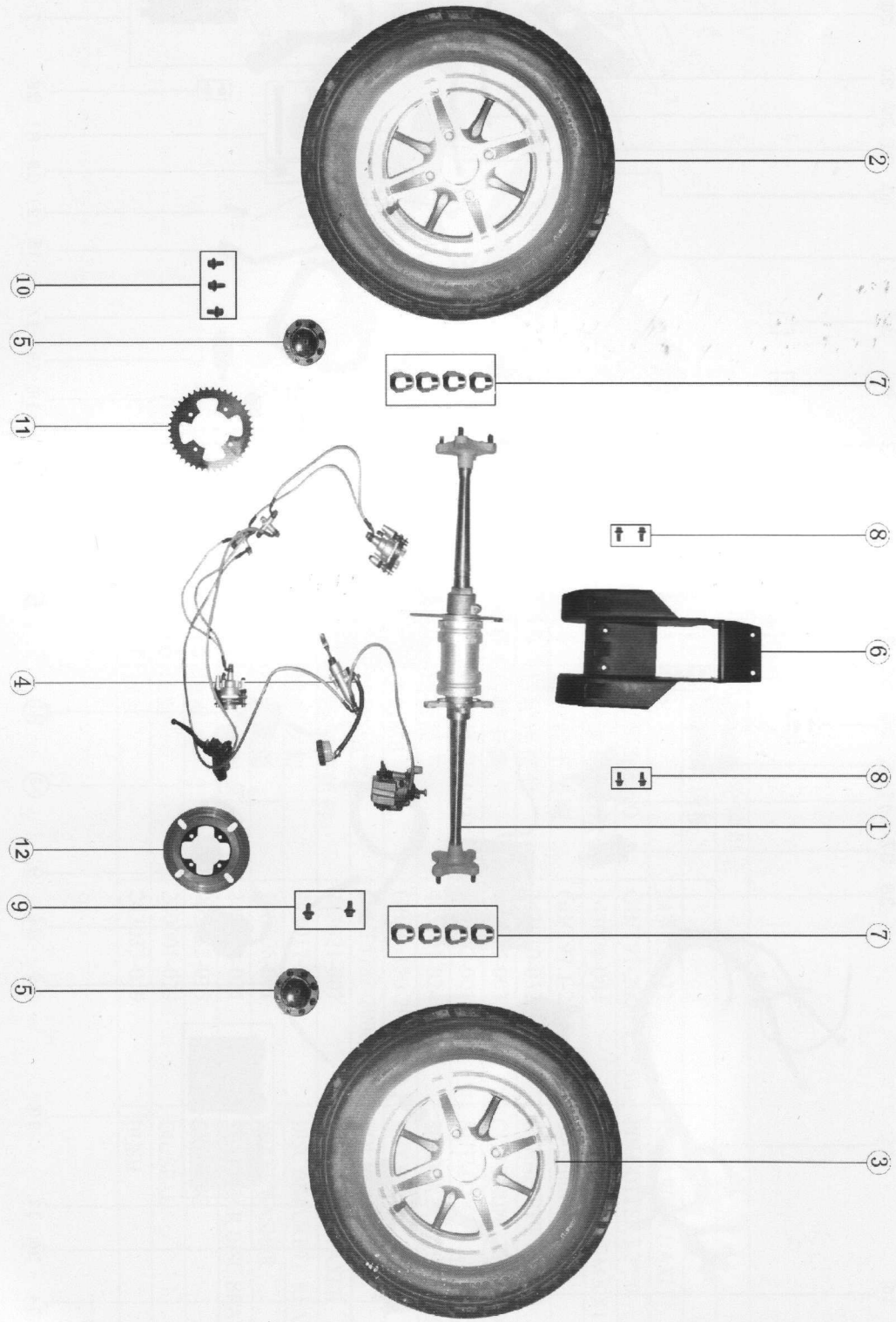

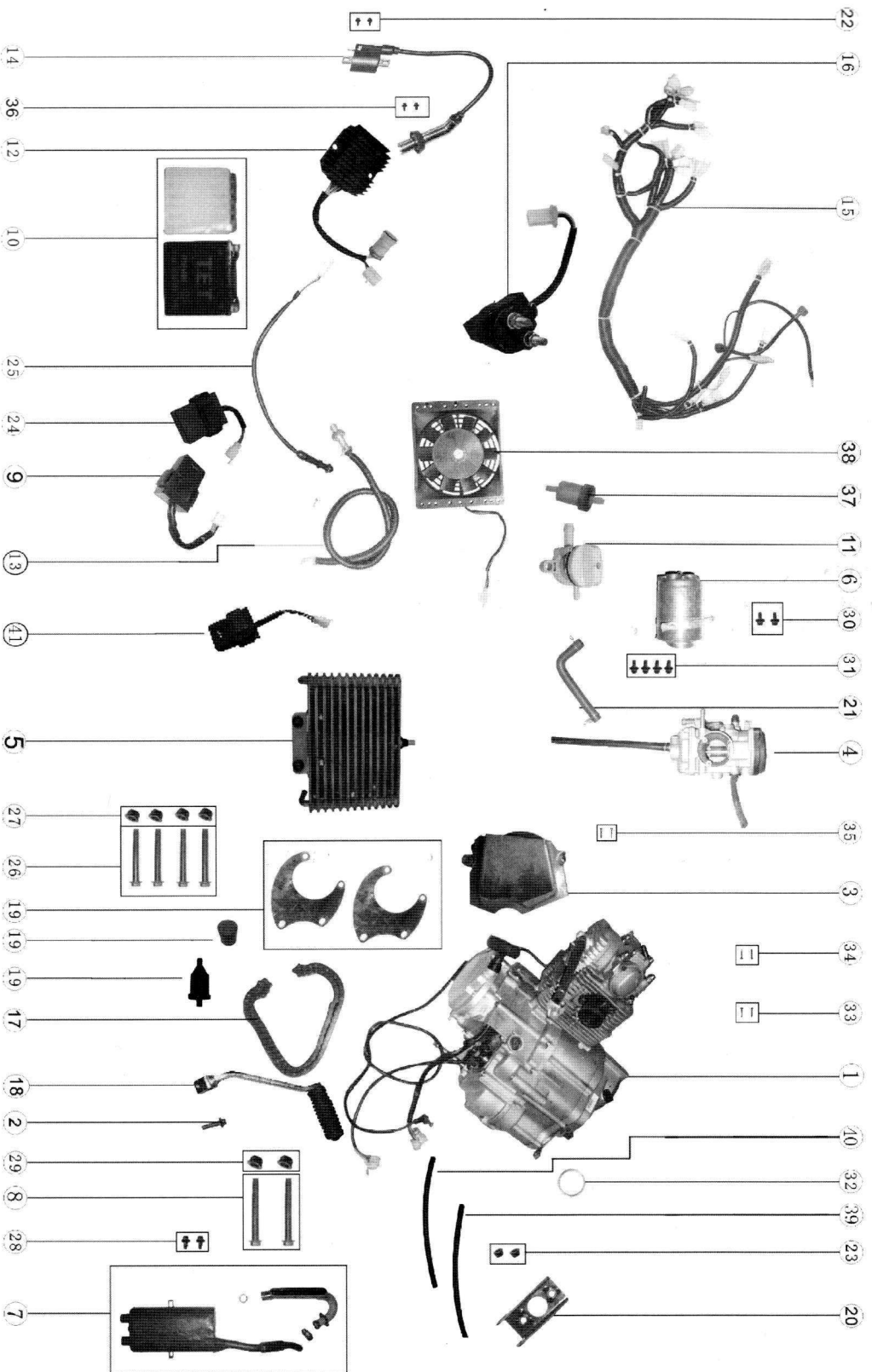

ENGINE & WIRING ASSEMBLY (2)

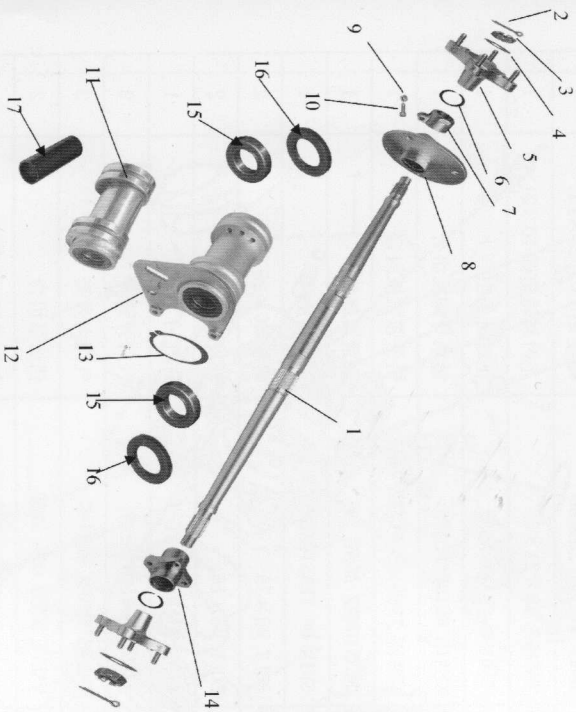

BS300S-18后轮轴组合		
序号	名称及规格	
1	后轮轴	243012-032
2	开口销3.2*50	GB/T91-2000 3.2*50
3	开槽螺母M20X1.5	243028-004
4	后轮毅平垫圈	GB/T97.1-2002
5	后轮连接盘	243010-032
6	后桥卡簧	243025-003
7	锁紧螺母M42X1	243022-001
8	链盘座	405101-024
9	螺母M8	GB/T6170-2000
10	螺栓M8*25	GB/T5783-2000
11	后桥套管组件	243021-007
12	碟刹支架	243017-009
13	轴用挡圈	106206-001
14	后桥碟刹座	243016-021
15	轴承	902012-013
16	油封	240001-039
17	衬套	243033-019

REAR WHEEL AXLE ASSY (7)

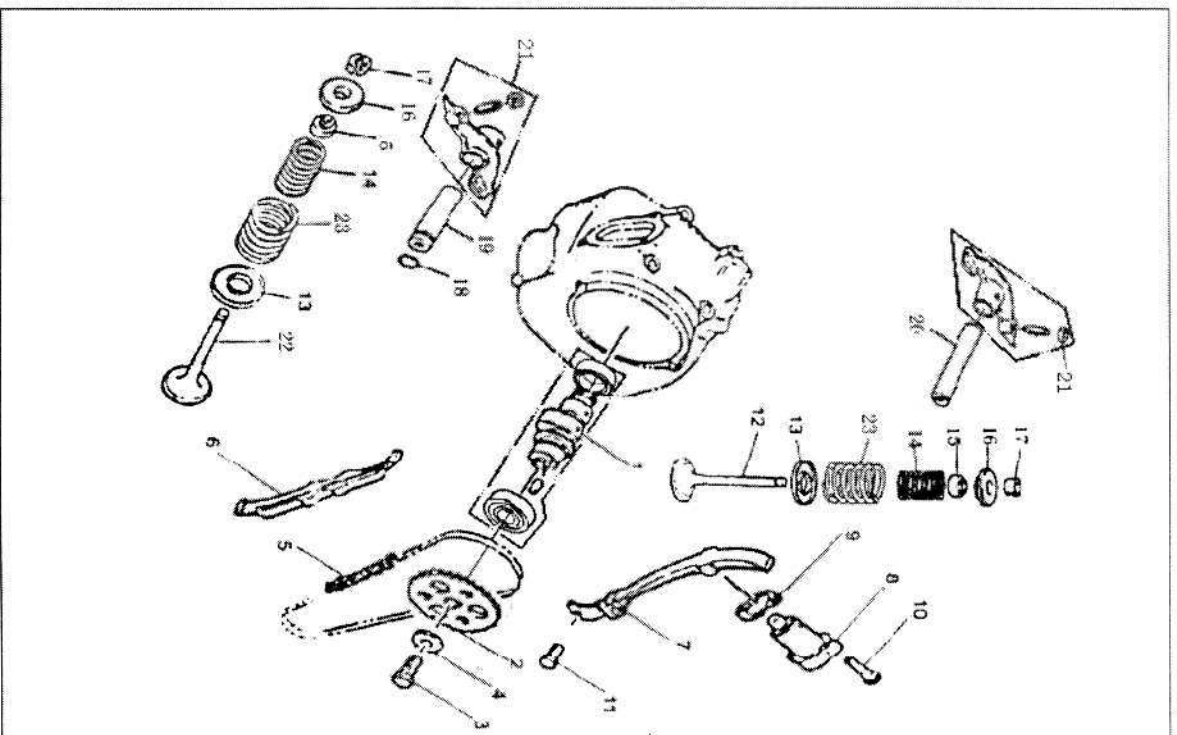
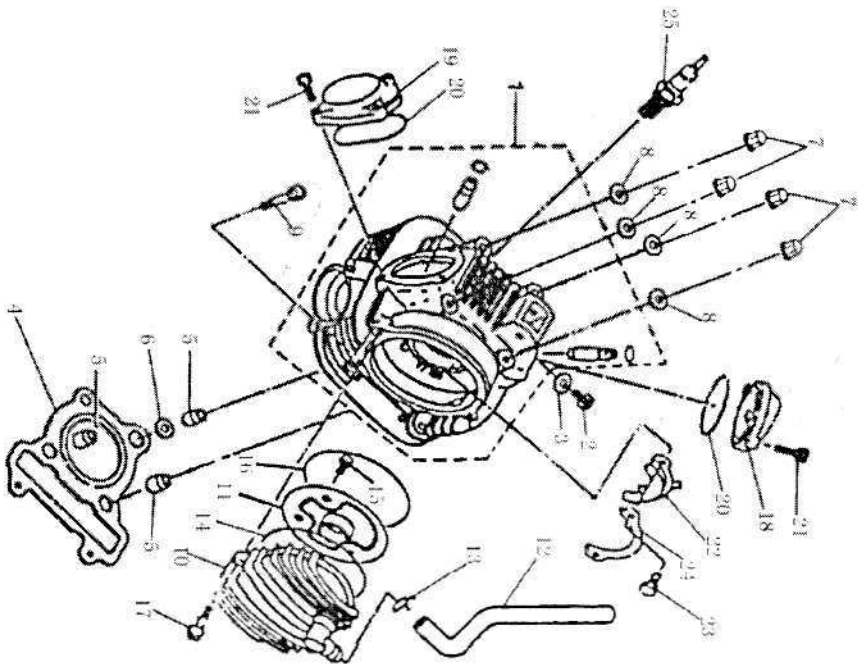

FIG. 1 PNEUMATIC MECHANISM

REF. NO.	PART NO.	DESCRIPTION	名称	Q'TY
1	104130-048	PNEUMATIC CAM SHAFT ASSY	凸轮轴组合	1
2	104170-001	TIMING SPROCKET	正时从动链轮组合	1
3	115100-004	BOLT M10×L.25×25	螺栓 M10×L.25×25	1
4	104109-001	WASHER 10×21×3	正时链轮垫圈 10×21×3	1
5	104150-017	TIMING CHAIN ASSY	正时链条组合	1
6	104250-001	CHAIN GUIDE PLATE	链条导向板组合	1
7	104240-001	CHAIN TENSION PLATE ASSY	链条张紧板组合	1
8	104200-009	TENSIONER ASSY	张紧器部件	1
9	104209-008	SHIM OF TENSIONER	张紧器垫片	1
10	115100-005	BOLT M6×25	螺栓 M6×25	2
11	115100-015	BOLT M6×16	螺栓 M6×16	2
12	104301-027	AIR INTAKE VALVE	进气门	1
13	104307-016	VALVE SPRING SEAT	气门弹簧座	2
14	104303-016	VALVE INNER SPRING	气门内弹簧	2
15	104310-015	VALVE STEM OIL SEAL	机油罩组合	2
16	104306-013	VALVE SPRING UPPER SEAT	气门弹簧上座圈	2
17	104308-015	VALVE LOCK CLIP	气门锁夹	4
18	102209-002	O-RING 8.8×1.9	O形圈 8.8×1.9	1
19	104413-016	AIR EXHAUST ROCKER SHAFT	排气摇臂轴	1
20	104413-017	AIR INTAKE ROCKER SHAFT	进气摇臂轴	1
21	104410-017	VALVE ROCKER SHAFT ASSY	气门摇臂组合	2
22	104302-027	AIR EXHAUST VALVE	排气门	1
23	104304-016	VALVE OUTER SPRING	气门外弹簧	2

FIG. 2 CYLINDER CAP



REF. NO.	PART NO.	DESCRIPTION	名称	QTY
1	102210-323	CYLINDER CAP UNIT	气缸头组合	1
2	115100-009	BOLT M6×10	螺栓 M6×10	1
3	106109-004	COPPER WASHER	铜垫圈	1
4	102230-048	CYLINDER CAP SHIM UNIT	气缸头密封垫	1
5	116108-003	ALIGNMENT PIN 12×16	定位销 12×16	3
6	102213-001	RECTANGULAR RING 12×16×8	矩形密封圈 12×16×8	1
7	102218-013	CAP NUT M6	盖形螺母 M6	4
8	102219-008	WASHER	铜垫圈 8	4
9	115100-002	BOLT M8×45 10.9级	螺栓 M8×45 10.9级	2
10	102305-001	LEFT CORNER OF CYLINDER CAP UNIT	气缸头左盖组合	1
11	102212-002	OIL BAFLE UNIT	挡油盘组合	1
12	1101202-019	AIR DRAIN	通气管	1
13	101203-012	HOOP OF AIR DRAIN	通气管夹簧	1
14	102211-006	O-RING 105×2	缸头左侧盖 O形圈 105×2	1
15	115100-010	BOLT M6×12	螺栓 M6×12	2
16	102225-002	O-RING 91×3	挡油盘 O形圈 91×3	1
17	115100-011	BOLT M6×10	螺栓 M6×10	2
18	102207-018	AIR INTAKE VALVE COVER	进气门室盖	1
19	102207-019	AIR EXHAUST VALVE COVER	排气门室盖	1
20	10208-006	O-RING 56.2×2.4	O形圈 56.2×2.4	2
21	115100-003	BOLT M6×18	内六角螺栓 M6×18	5
22	102216-011	PRESSURE PLATE OF ROCKER ARM SHAFT	摇臂轴压板	1
23	115100-012	BOLT M6×18	螺栓 M6×18	2

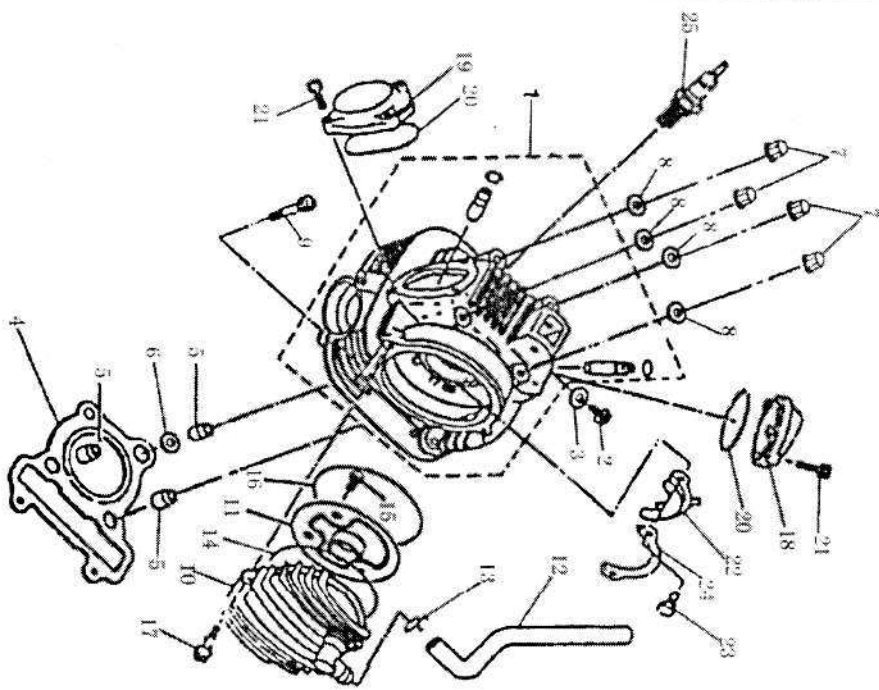

FIG. 2 CYLINDER CAP

REF. NO.	PART NO.	DESCRIPTION	名称	Q'TY
24	102215-001	PRESSURE PLATE OF CAM SHAFT	凸轮轴压板	1
25	102250-019	SPARK PLUG	火花塞	1

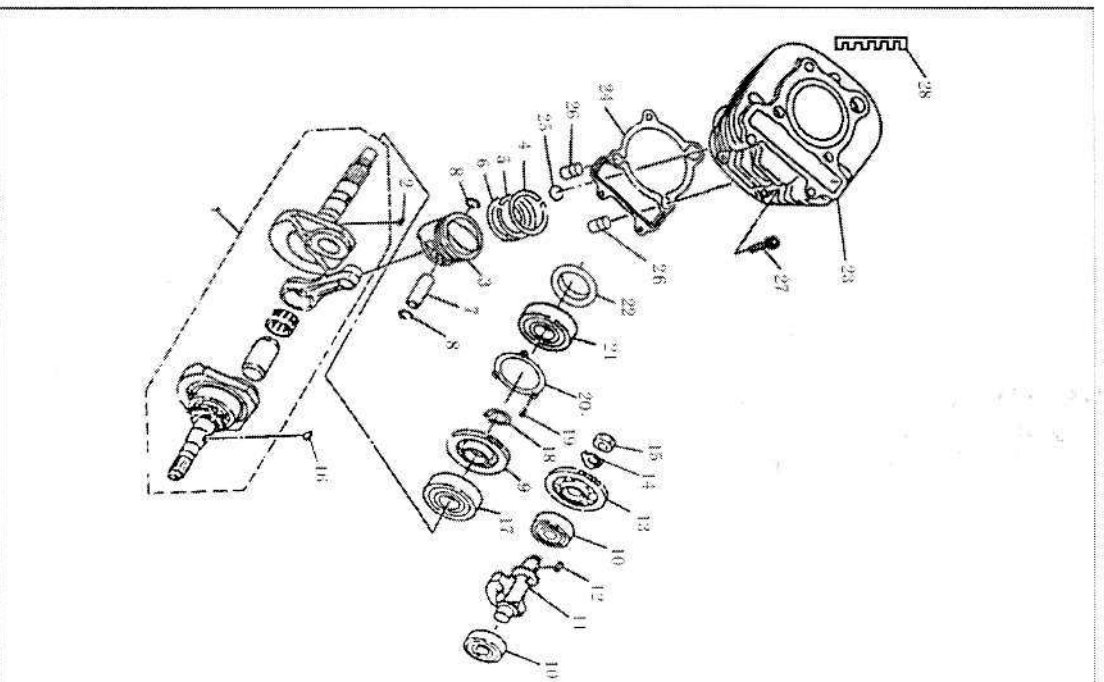

FIG. 3 CRANK CONNECTING ROD MECHANISM

REF. NO.	PART NO.	DESCRIPTION	名称	Q'TY
1	103200-082	CRANK CONNECTING ROD ASSY	曲轴连杆部件	1
2	103203-014	WOODRUFF KEY 3×5×10	半圆键 3×5×10	1
3	103101-046	PISTON	活塞	1
4	103104-037	PISTON RING 1	第一道活塞环	1
5	103105-035	PISTON RING 2	第二道活塞环	1
6	103110-010	OIL RING UNIT	油环组合	1
7	103102-024	PISTON PIN	活塞销	1
8	103103-019	CIRCLIP OF PISTON PIN	活塞销挡圈	2
9	103302-006	BALANCE SHAFT DRIVING GEAR	平衡轴主动齿轮	1
10	116210-004	BEARING 6304	轴承 6304	2
11	103301-001	BALANCE SHAFT	平衡轴	1
12	103304-006	FLAT KEY 5×5×8	平键 5×5×8	1
13	103303-006	BALANCE SHAFT GEAR	平衡轴从动齿轮	1
14	103305-005	BALANCE SHAFT LOCKING WASHER 14	平衡轴锁紧垫圈 14	1
15	103306-004	LOCKING NUT M14	锁紧螺母 M14	1
16	103203-015	WOODRUFF KEY 5×5.7×12	半圆键 5×5.7×12	1
17	116210-005	BEARING 6306/75	轴承 6306/75	1
18	103307-003	CIRCLIP 26	挡圈 26	1
19	115200-002	BOLT M6×18	螺栓 M6×18	3
20	101417-001	BEARING OF RIGHT COVER PRESSURE PLATE	右盖轴承压板	1
21	116210-006	BEARING 6203	轴承 6203	1
22	107230-017	OIL SEAR 17×29×5	油封 17×29×5	1
23	102120-068	CYLINDER UNIT	气缸体组合	1

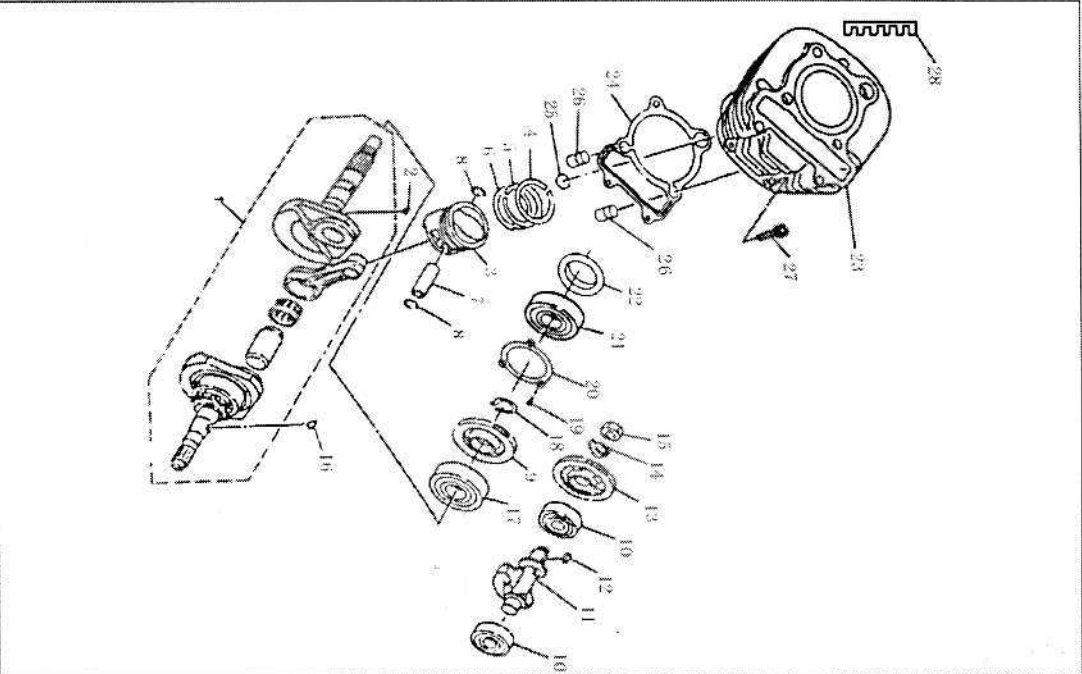

FIG. 3 CRANK CONNECTING ROD MECHANISM

REF. NO.	PART NO.	DESCRIPTION	名称	QTY
24	102108-035	CYLINDER SHIM	气缸体密封垫	1
25	102209-001	O-RING 13×2.5	O形圈 13×2.5	1
26	116108-003	ALIGNMENT PIN 12×16	定位销 12×16	2
27	115400-001	BOLT M6×25	内六角螺栓 M6×25	2
28	102101-001	DAMPER	缸体减振胶块	2

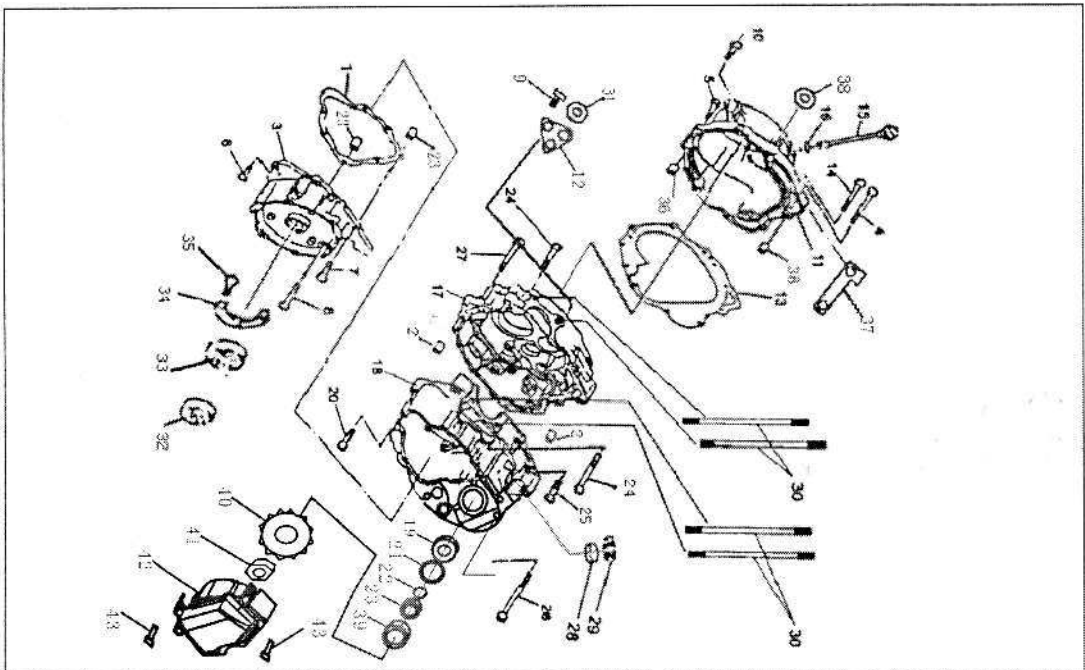

FIG. 4 CRANKCASE BODY PART

REF. NO.	PART NO.	DESCRIPTION	名称	QTY
1	101301-020	LEFT CRANKCASE FRONT COVER GASKET	左曲轴箱前盖密封垫	1
2	116108-002	ALIGNMENT PIN 12×16	定位销 12×16(包括合箱)	2
3	101303-001	LEFT CRANKCASE COVER ASSY	左曲轴箱盖部件	1
4	115100-001	BOLT M6×35	螺栓 M6×35(倒挡拉板)	1
5	115100-001	BOLT M6×35	螺栓 M6×35(连接板)	2
6	115100-005	BOLT M6×25	螺栓 M6×25	1
7	115100-002	BOLT M6×32	螺栓 M6×32	1
8	115100-006	BOLT M6×40	螺栓 M6×40	5
9	115200-002	BOLT M6×18	螺栓 M6×18	2
10	115100-005	BOLT M6×25	螺栓 M6×25	6
11	101401-296	RIGHT CRANKCASE COVER	右曲轴箱盖	1
12	106117-001	DETACHED PLATE OF CLUTCH	离合器分离板	1
13	101403-025	RIGHT CRANKCASE COVER GASKET	右曲轴箱盖密封垫	1
14	115100-002	BOLT M6×32	螺栓 M6×32(倒挡拉板)	1
15	101440-001	OIL DIPSTIC UNIT	机油尺组合	1
16	101442-009	OIL DIPSTIC O-RING 19×2.4	机油尺 O 形圈 19×2.4	1
17	101200-001	RIGHT CRANKCASE ASSY	右曲轴箱部件	1
18	101100-001	LEFT CRANKCASE ASSY	左曲轴箱部件	1
19	116210-003	BEARING 6304	轴承 6304	1
20	115100-005	BOLT M6×25	螺栓 M6×25	7
21	116109-002	ADJUSTING WASHER UNIT	调整垫片组	1
22	113212-007	O-RING 19×2	O 形圈 19×2	1
23	107217-002	SPROCKET WHEEL SHAFT LINER	链轮轴套	1

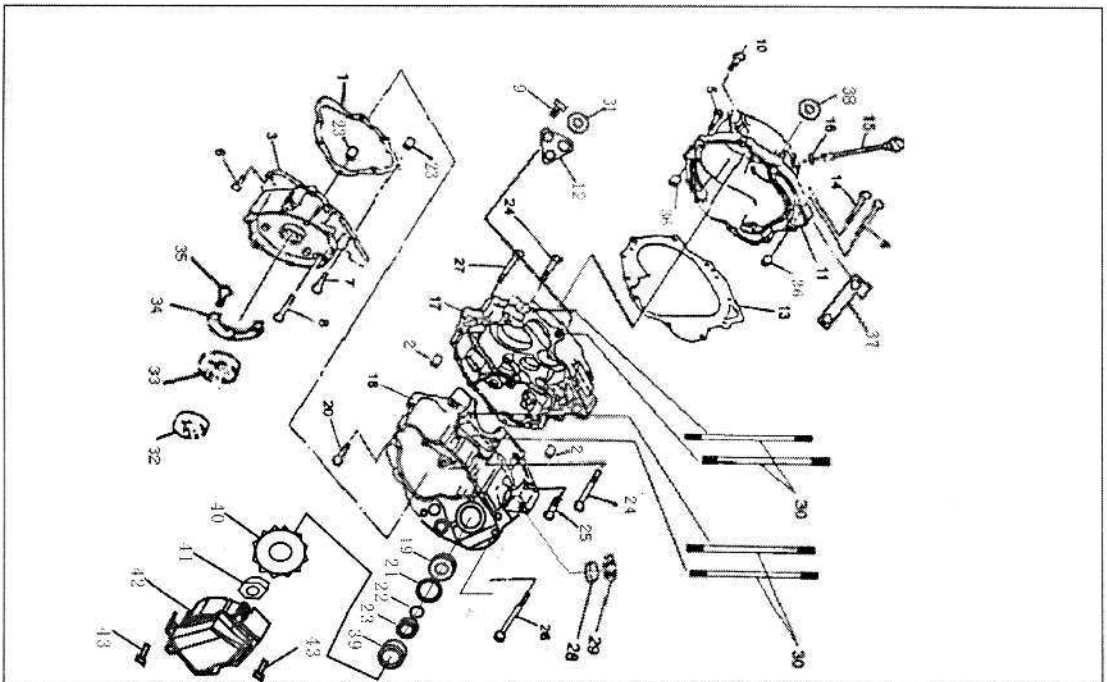

FIG. 4 CRANKCASE BODY PART

REF. NO.	PART NO.	DESCRIPTION	名称	QTY
24	115100-001	BOLT M6×50	螺栓 M6×50	2
25	115100-002	BOLT M6×32	螺栓 M6×32	1
26	115100-003	BOLT M6×160	螺栓 M6×160	1
27	115100-004	BOLT M6×35	螺栓 M6×35	1
28	101126-001	SPRUE 26×6	油道堵头 26×6	1
29	101127-004	CIRCLIP 28	内挡圈 28	1
30	101103-024	DOUBLE-HEAD BOLT	双头螺栓	4
31	118109-001	WASHER 12×22×2	垫圈 12×22×2	1
32	108224-006	CRANK SHAFT LEFT OIL SEAR	曲柄左油封 28×40×8	1
33	116210-002	BEARING 60/28	轴承 60/28	1
34	109504-001	PRESSURE PLATE	手起油盖轴承压板	1
35	115200-001	SCREW M5×16	螺钉 M5×16	3
36	116108-001	ALIGNMENT PIN 8×14	定位销 8×14	2
37	107402-003	BRAKLET OF GUY CABLE	倒杆操纵板拉索支架	1
38	106303-006	OIL SEAR12×22×5	油封 12×22×5	1
39	107230-016	CRANKSHAFT OIL SEAL 25×40×8	曲轴油封 30×45×8	1
40	107221-027	INITIATIVE SPROCKET WHEEL	主动链轮	1
41	107364-001	LOCKNT	防松螺母	1
42	101302-179	CALTA COVER	左曲轴箱后盖	1
43	115100-004	BOLT M6×35	螺栓 M6×35	2

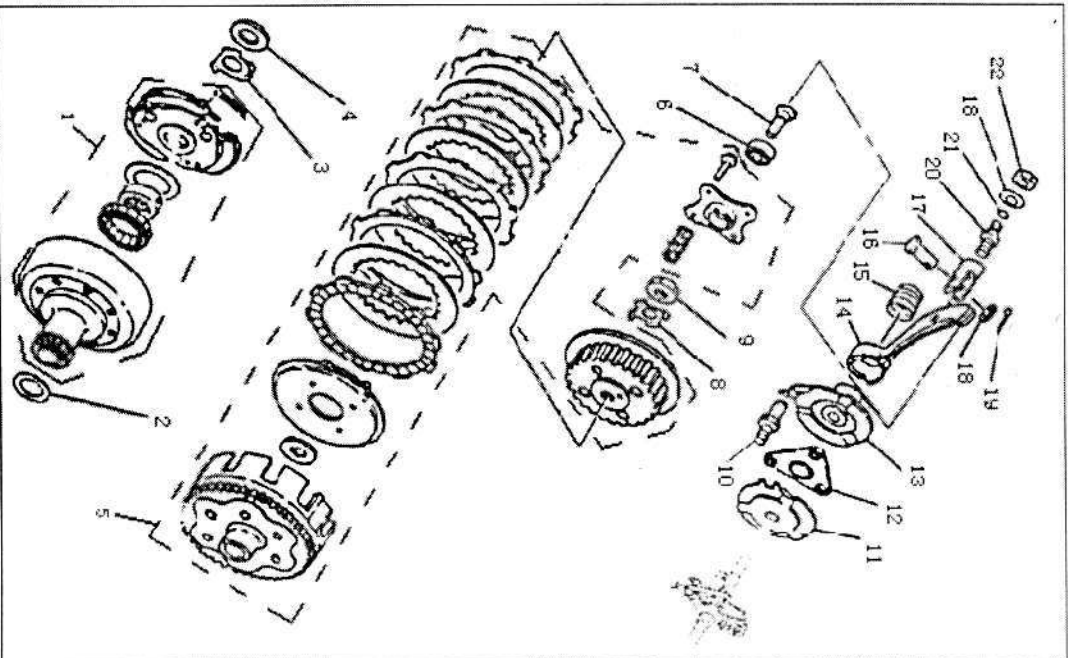

FIG. 5 CLUTCH

REF. NO.	PART NO.	DESCRIPTION	名称	QTY
1	106500-004	PRIMARY CLUTCH ASSY	初级离合器组件	1
2	106102-006	HALT WASHER	止推垫圈 26	1
3	106116-002	INTERNAL TAB WASHER 22	内舌止功垫圈 22	1
4	106111-001	NUT M22×1	螺母 M22×1	1
5	106200-001	MASTER CLUTCH	主离合器部件	1
6	116210-001	BEARING 6000	轴承 6000	1
7	106313-007	CLUTCH PUSH ROD	离合推杆	1
8	106116-001	INTERNAL TAB WASHER 14	内舌止功垫圈 14	1
9	106111-002	NUT M14×1	螺母 M14×1	1
10	108201-001	GEAR SHIFTING FITTING BOLT	换挡定位螺栓	1
11	106132-004	DETACHING CAM LOWER PLATE	分离凸轮下板	1
12	106150-005	STEEL BALL BRACKET UNIT	钢球架组合	1
13	106130-001	UPPER PLATE OF CAM UNIT	上凸轮板组合	1
14	106321-001	OPERATION ROCKER ARM UNIT	离合器操纵杆	1
15	108209-003	COMPRESSED SPRING OF DETACHING ARM	分离臂弹簧	1
16	106317-002	CONNECTING PIN	连接销	1
17	106316-002	SUPPORT SEAT	支撑座	1
18	106311-003	ADJUSTING SCREW PLAIN WASHER 8	调节螺钉平垫圈 8	2
19	106312-007	COTTER PIN 1.4×16	开1.4×16	1
20	106307-005	ADJUSTING SCREW	调节螺钉	1
21	106309-004	ADJUSTING SCREW O-RING 8×2.5	调节螺钉 O 形圈 8×2.5	1
22	106308-004	ADJUSTING NUT M8	调节螺母 M8	1

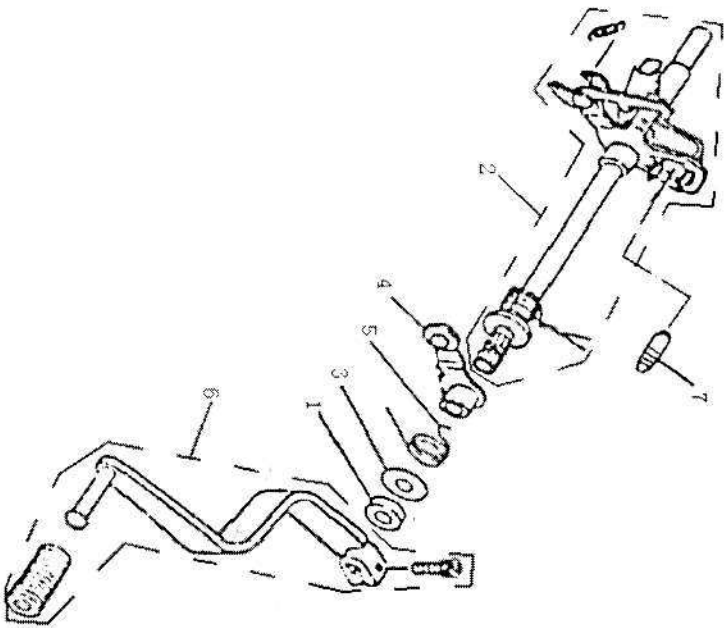

FIG. 6 GEAR SHIFT OPERATION DEVICE

REF. NO.	PART NO.	DESCRIPTION	名称	Q'TY
1	106303-006	OIL SEAL 12×22×5	油封 12×22×5	1
2	108200-029	SHIFT AXLE ASSY	换挡轴部件	1
3	108208-004	WASHER OF SHIFT AXLE	换挡轴垫圈	2
4	108130-016	POSITIONING BOARD UNIT	定位板组合	1
5	108104-012	TORSIONAL SPRING	定位板弹簧	1
6	211000-029	SHIFT PEDAL ASSSY	换挡踏板总成	1
7	108201-001	FITTING BOLT OF SHIFT AXLE	换挡定位螺栓	1

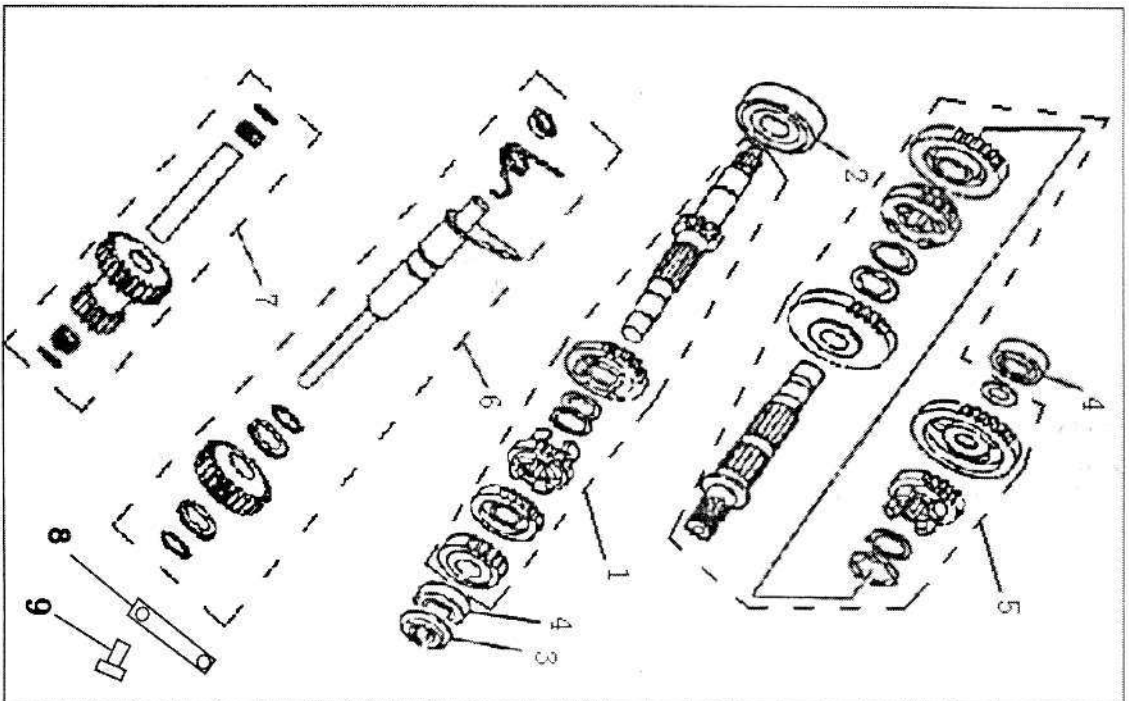

FIG. 7 CHANGE SPEED GEAR DEVICE

REF. NO.	PART NO.	DESCRIPTION	名称	QTY
1	107100-051	PRINCIPAL AXIS ASSY	主轴部件	1
2	116210-007	BEARING 6204/P6	轴承 6204/P6	1
3	107115-003	PRINCIPAL AXIS OIL SEAL 15×28×3.5	主轴油封 15×28×3.5	1
4	116210-008	BEARING 6202/P6	轴承 6202/P6	2
5	107200-071	COUNTERSHAFT ASSY	副轴部件	1
6	107330-009	IDLER WHEEL ASSY	惰轮齿组合	1
7	107340-010	REVERSE IDLER GEAR	倒档双联齿组合	1
8	107341-004	CONTROL PLATE OF REVERSE GEAR	倒档拨板	1
9	115100-013	BOLT M6×12	螺栓 M6×12	1

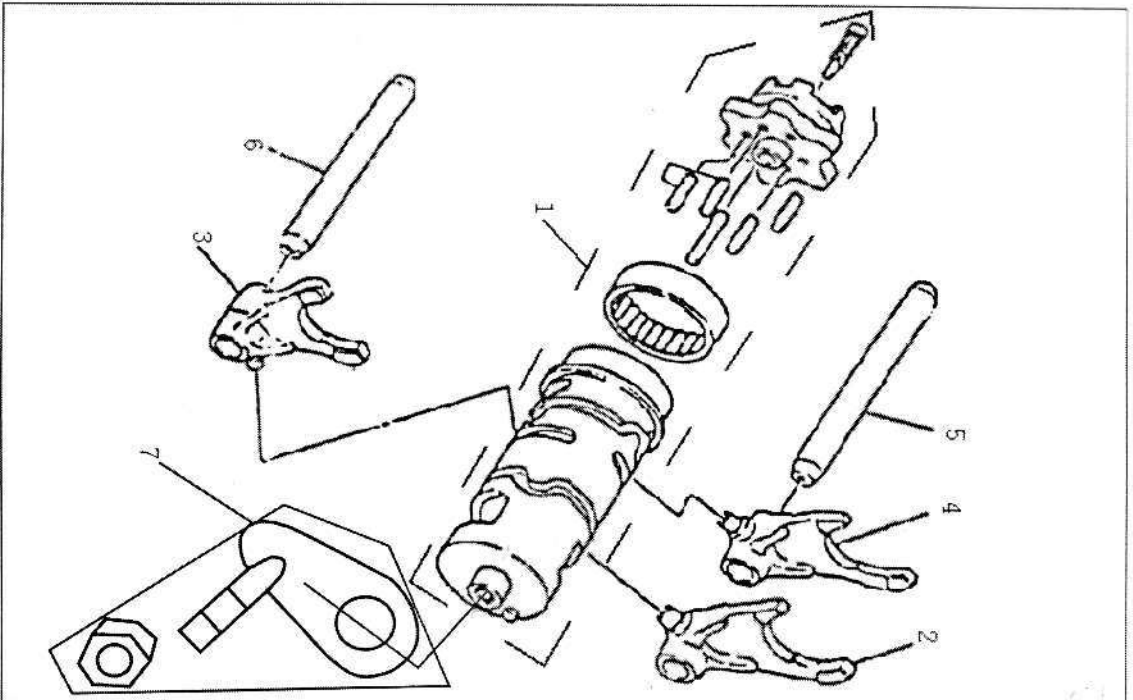

FIG. 8 SHIFT CAM, SHIFT FORK DEVICE

REF. NO.	PART NO.	DESCRIPTION	名称	QTY
1	108110-039	SHIFT CAM AXLE ASSY	变速鼓组合	1
2	108121-012	LEFT SHIFT FORK	换挡左拨叉	1
3	108122-011	MIDDLE SHIFT FORK	换挡中拨叉	1
4	108123-011	RIGHT SHIFT FORK	换挡右拨叉	1
5	108126-011	SHIFT FORK AXLE 2	拨叉轴 2	1
6	108126-012	SHIFT FORK AXLE 1	拨叉轴 1	1
7	113200-065	GEAR SHOW ASSY	档位显示部件	1

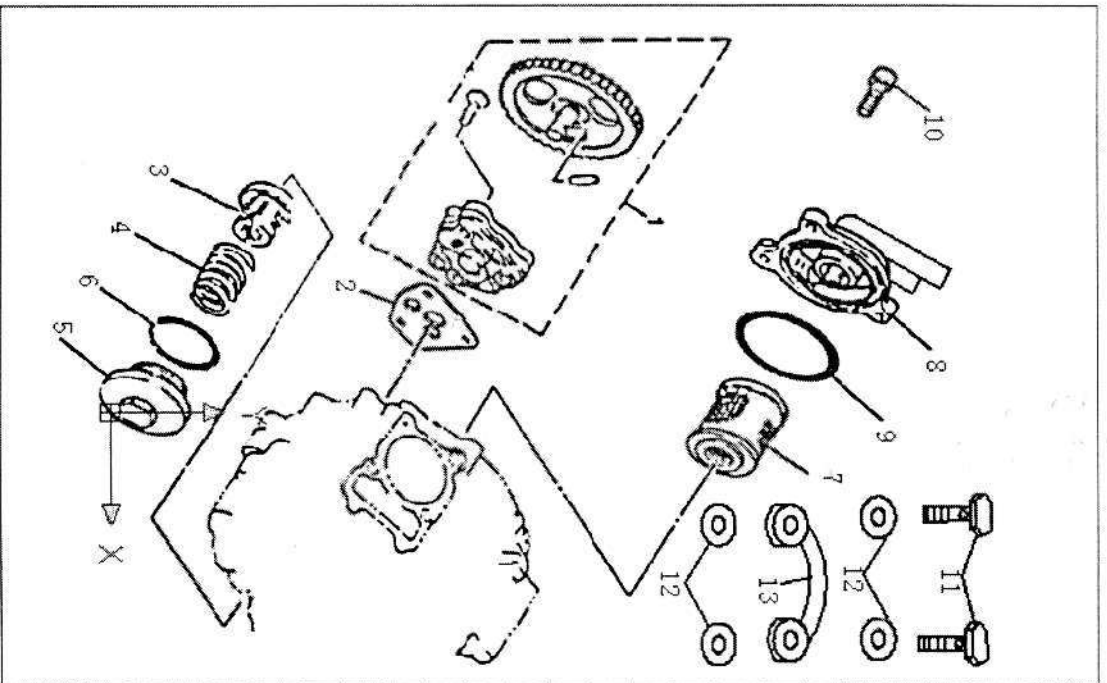

FIG. 9 LUBRICATIO SYSTEM

REF. NO.	PART NO.	DESCRIPTION	名称	Q'TY
1	105110-010	OIL PUMP ASSY	机油泵组合	1
2	105104-008	OIL PUMP GASKET	机油泵密封垫	1
3	101130-008	OIL GAUZE FILTER ASSY	机油过滤器组合	1
4	101116-011	OIL GAUZE FILTER SPRING	机油过滤器弹簧	1
5	105206-003	OIL GAUZE FILTER COVER	机油过滤器盖	1
6	101118-007	GAUZE FILTER COVER O-RING	滤网盖 O 形圈	1
7	105200-014	Lubricating oil filter	机油滤清器零件	1
8	105230-001	LUBRICATING OIL FILTER COVER ASSY	机油过滤器盖组合	1
9	105211-004	O-RING 53.5X2.3	O 形圈 53.5X2.3	1
10	116101-001	BOLT M6X25	螺栓 M6X25	3
11	101206-004	THROUGH OIL BOLT M10	通油螺栓 M10	2
12	116109-004	COPPER WASHER	铜垫圈 10	4
13	101230-005	INSIDE VITTA UNIT	内油管组合	1

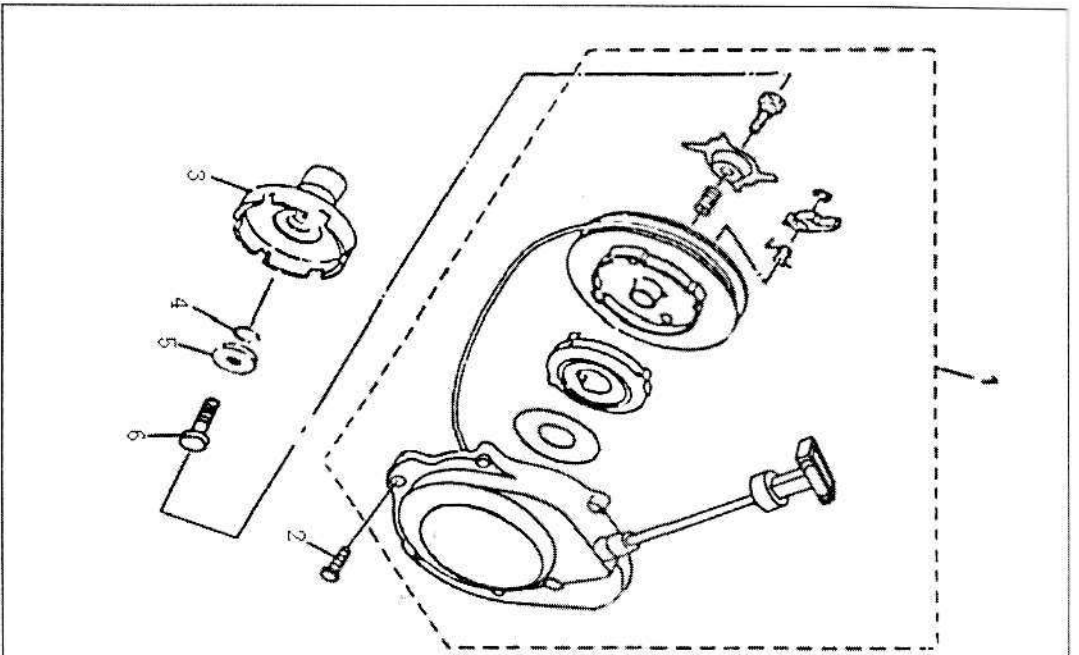

FIG. 10 HAND STARTING

REF. NO.	PART NO.	DESCRIPTION	名称	QTY
1	109530-003	HAND STARTING DEVICE	手启动器组合	1
2	115100-008	BOLT M6×20	螺栓 M6×20	6
3	109550-004	BOSS ONE-WAY UNIT	启动棘轮组合	1
4	109502-002	BOSS ONE-WAY O-RING 16.5×3.2	启动棘轮 O 形圈 16.5×3.2	1
5	109503-003	WASHER 11×30×5	垫圈 11×30×5	1
6	109505-001	BOLT M10×1.25×40	螺栓 M10×1.25×40	1

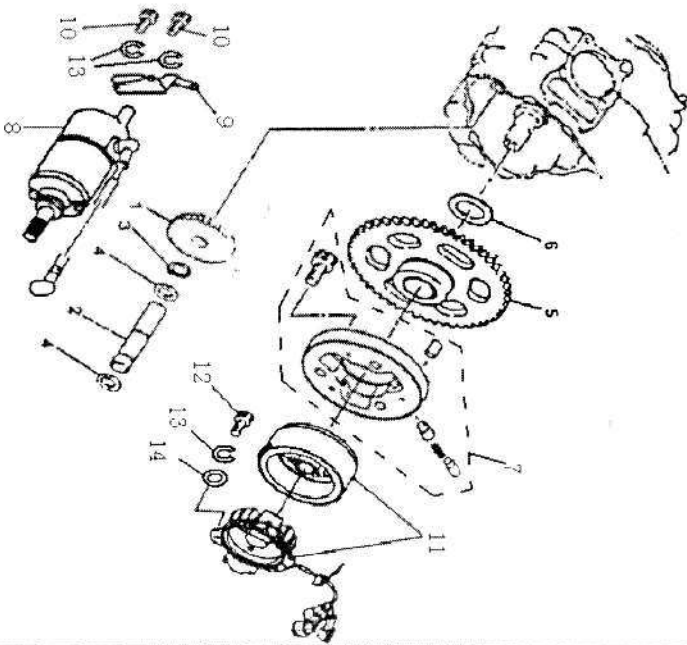

FIG. 11 ELECTRIC STARTER

REF. NO.	PART NO.	DESCRIPTION	名称	QTY
1	109231-010	DUAL GEAR	双联齿轮	1
2	109221-010	DUAL GEAR SHAFT	双联齿轮轴	1
3	116109-003	THRUST WASHER 12	止推垫圈 12	1
4	109205-002	CLOSING RING 12	挡圈 12	2
5	106102-006	THRUST WASHER 16	止推垫圈 16	1
6	109210-013	DISK TYPE GEAR	盘形齿轮组合	1
7	109100-011	OVER RUNNING CLUTCH	超越离合器部件	1
8	112000-118	STARTING MOTOR ASSY	启动电机组件	1
9	101123-001	CONNECTING BOARD OF STARTING MOTOR	启动电机连接板	1
10	113100-007	BOLT M6 X 15	螺栓 M6 X 15	2
11	111000-017	MAGNETO ASSY	磁电机组件	1
12	113200-003	SCREW M6 X 25	螺钉 M6 X 25	3
13	115300-001	BELICAL SPRING LOCKWASHER 6	弹簧垫圈 6	2

FRAME ASSEMBLY

零部件目录 PART CATELAG

序号 S/N	零部件代号 Part No.	Description	零部件名称 Part name	数量 Quantity
1	511000-291	FRAME ASSY	车架焊接总成	1
2	512100-126	BUMPER	保险杠	1
3	332200-004	SUPPORT, REAR LAMP	尾灯支架	1
4	501300-054	FRONT SHOCK ABSORBER	前减震器	2
5	507400-039	LEFT-DOWN SWING ARM	左下摇臂	1
6	507600-039	RIGHT-DOWN SWING ARM	右下摇臂	1
7	507300-036	LEFT-UP SWING ARM	左上摇臂	1
8	507500-036	RIGHT-UP SWING ARM	右上摇臂	1
9	230010-007	TENSION PULLEY	张紧轮	1
10	536600-020	PROTECT PEDAL	护脚网	2
11	100001-004	PROTECT PLATE, ENGINE	发动机底罩	1
12	805809-001	LEFT SUPPORT, REAR FENDER	后挡泥左支架	1
13	805502-004	RIGHT SUPPORT, REAR FENDER	后挡泥右支架	1
14	430400-030	REAR BRAKE PEDAL	后制动踏板	1
15	536100-009	LEFT PEDAL	脚踏板	2
16	804005-009	LEFT SUPPORT FRONT FENDER	前挡泥左支架	1
17	540300-053	REAR SHOCK ABSORBER	后减震器	1
18	713400-005	REAR RIDER	后扶手	1
19	360600-003	CABLE SEAT	座垫拉索	1
20	713500-001	REAR LEFT ARMREST	左后扶手	1
21	523100-055	FEAR ARM ASSEMBLY	平叉总成	1
22	303001-011	BOX, BATTERY	蓄电池盒	1
23	902001-017	HEXANGULAR AXLE	六角头轴	1
24	804006-009	RIGHT SUPPORT FRONT FENDER	前挡泥右支架	1
25	507700-003	PLATE, SWING ARM	摇臂护板	2

26	800005-001	MIDDLE PLATE SUPPORT	油箱护板支架	2
27	GB5787-2000	BOLT M10×58	螺栓M10×60	10
28	GB5787-2000	BOLT M10×40	螺栓M10×40	1
29	GB5787-2000	BOLT M6×10	螺栓M6×10	2
30	430001-008	REAR BRAKE RESET SPRING	后制动回位簧	1
31	805102-001	SUPPORT, REAR L. FENDER	后左挡泥支承	1
32	GB/T97-2002	WASHER 8	平垫8	2
33	GB5787-2000	BOLT M10×25	螺栓M10×25	4
34	533000-001	REAR LEFT FOOTREST	后左搁脚总成	1
35	GB5787-2000	BOLT M8×40	螺栓M8×40	4
36	GB6187-2000	NUT M14	螺母M14	1
37	GB5787-2000	BOLT M6×16	螺栓M6×16	4
38	GB5787-2000	BOLT M8×16	螺栓M8×16	4
39	GB5787-86	BOLT M6×20	螺栓M6×20	4
40	GB5787-2000	BOLT M6×16	螺栓M6×16	2
41	430002-003	REAR BRAKE SWITCH SPRING	后制动开关簧	1
42	713600-001	REAR RIGHT ARMREST	右后扶手	1
43	303002-007	BATTERY COVER	蓄电池盖	1
44	430003-002	SPRING, TENSIONER	张紧器弹簧	1
45	534000-001	REAR-RIGHT FOOTREST ASSY	后右搁脚总成	1
46	805101-001	SUPPORT REAR FENDER	后右挡泥支承	1
47	802001-003	FUEL SWITCH SUPPORT	燃油开关支架	1
48	904201-002	CLIP, CHAIN	链条护卡	1

FRONT WHEEL ASSEMBLY

零部件目录 PART CATELAG

序号 S/N	零部件代号 Part No.	Description	零部件名称 Part name	数量 Quantity
1	400100-001	FRONT TYRE	前轮胎	2
2	402000-001	FRONT TYRE HUB	前轮毂	2
3	505000-018	STEERING PARTS	转向节部件	2
4	441600-007	FRONT DISK-BRAKED SEAT	前碟刹基座	2
5	430500-014	ROD ASSY	拉杆组件	2
6	904206-005	DUSTPROOF RUBBER BOOT	防尘护套	2
7	GB/T91-2000	PIN COTTER 2×20	开口销2×20	4
8	441001-014	FRONT BRAKE DISC	前碟刹盘	2
9	GB/T97.1-2000	WASHER10	平垫圈	4
10	GB/T93-1987	SPRING WASHER 10	弹垫10	4
11	906160-008	COVER NUT M10	盖形螺母M10	8
12	GB/T91-2000	PIN COTTER 2.5×30	开口销2.5×30	2
13	GB6181-2000	NUT M14	螺母M14	2
14	GB/T97.1-2000	WASHER14	平垫圈14	2
15	GB6181-2000	NUT M10	螺母M10	4

FRONT FORK ASSEMBLY

零部件目录 PART CATELAG

序号 S/N	零部件代号 Part No.	Description	零部件名称 Part name	数量 Quantity
1	503300-067	STEERING STEM	方向柱	1
2	601000-001	L.HANDLEBAR	左手把管	1
3	372100-015	LEFT HANDL COMP	左手手柄	1
4	350200-005	SUPPORT SPEED METER	仪表支架	1
5	602000-001	R.HANDLEBAR	右手把管	1
6	600201-006	THROTTLE ASSY	加油器	1
7	250200-011	REVERSE CABLE	倒档拉索	1
8	607000-028	CABLE,THROTTLE	油门拉索	1
9	430600-015	REAR BRAKE CABLE	后制动拉索	1
10	610000-024	WIND-RESISTED CABLE	阻风门拉索	1
11	371100-023	LEFT HANDLEBAR SWITCH	左闸把开关	1
12	503311-001	STEERING LIMIT DOLLOP	方向柱限位块	1
13	GB5782-2000	BOLT M8×60(70)×1.25	螺栓M8×60(70)×1.25	4
14	904303-015	HANDLE BAR CLUE	手把胶	2
15	901010-001	CLIP, MIRROR SEAT	镜座卡子	2
16	GB/T97.1-2000	WASHER 10	平垫圈10	1
17	GB6181-2000	NUT M10	螺母M10	1
18	GB/T91-2000	PIN COTTER 2.5×30	开口销2.5×30	1
19	312100-002	SINGLE HORN	单喇叭	1
20	901400-013	REARVIEW MIRROR	后视镜	2
21	351000-022	INSTRUMENT ASSY	仪表总成	1
22	252500-003	REVERSE LEVEL	倒档手柄	1
23	252000-002	REVERSE SUPPORT ASSY	倒档支架	1
24	360000-001	LOCK ASSY	锁具总成	1
25	510025-001	FRAME LIMIT DOLLOP	车架限位块	1
26	371104-001	EMERGENCY SWITCH	应急开关	1

COVERING PARTS ASSEMBLY

零部件目录 PART CATELAG

序号 S/N	零部件代号 Part No.	Description	零部件名称 Part name	数量 Quantity
1	800600-028	MIDDLE PLATE	油箱护板	1
2	805700-003	LEFT FENDER, REAR	后左挡泥	1
3	701000-072	SEAT CUSHION	座垫	1
4	333400-009	FRONT-LEFT STEERING LAMP	前左转向灯	1
5	333500-009	FRONT-RIGHT STEERING LAMP	前右转向灯	1
6	331000-026	HEAD LIGHT ASSY	前照灯总成	1
7	501302-001	LEFT COVER, FRONT SHOCK	前减右罩	1
8	801000-023	FUEL TANK ASSY	油箱总成	1
9	333700-009	REAR-RIGHT STEERING LAMP	后右转向灯	1
10	903200-001	TOOLS	随车工具	1
11	342000-001	PLACE LAMP	位置灯	1
12	904229-001	PAD 6	胶平垫 6	3
13	GB845-1985	BOLT ST4.2×16	螺钉ST4.2×16	3
14	333600-009	REAR-LEFT STEERING LAMP	后左转向灯	1
15	GB5787-2000	BOLT M6×16	螺栓M6×16	2
16	GB/T947-1988	BOLT M6×16	开槽球面大圆柱头螺钉M6×16	4
17	807100-085	FRONT FENDER	前面罩	1
18	906181-002	CLIP NUT	卡子螺母	4
19	804800-003	FRONT-LEFT FENDER	前左挡泥	1
20	501301-001	LEFT COVER, FRONT SHOCK	前减左罩	1
21	536400-017	LEFT PEDAL	左护脚网	1
22	805800-003	RIGHT FENDER, REAR	后右挡泥	1
23	306400-002	REAR REFLECTOR	后反射器	2
24	521000-001	BOX, UP CHAIN	上链盒	1
25	332000-017	REAR LAMP ASSY	尾灯总成	1
26	804700-003	RIGHT FENDER FRONT	前右挡泥	1
27	536500-016	RIGHT PEDAL	右护脚网	1
28	342002-001	PLACE LAMP SUPPORT	位置灯支架	1

REAR WHEEL ASSEMBLY

零部件目录 PART CATELAG

序号 S/N	零部件代号 Part No.	Description	零部件名称 Part name	数量 Quantity
1	243000-092	REAR BRIDGE ASSY	后桥总成	1
2	400100-001	REAR TYRE	后轮胎	2
3	402000-001	REAR TYRE HUB	后轮毂	2
4	443000-015	DISK BRAKE ASSY	碟刹总成	1
5	904206-005	DUSTPROOF RUBBER BOOT	防尘护套	2
6	245000-010	PROTECTING FRAME OF REAR BRIDGE	后桥护罩	1
7	906160-008	COVER NUT M10	盖形螺母M10	8
8	GB5787-2000	BOLT M8×16	螺栓M8×16	4
9	GB5787-2000	BOLT M6×18	螺栓M6×18	2
10	GB5787-2000	BOLT M6×20	螺栓 M6×20	3
11	405100-027	SPROCKET WHEEL	链轮	1
12	442001-014	REAR BRAKE DISC	后碟刹盘	1

ENGINE & WIRING ASSEMBLY

PART CATELAG

序号 S/N	零部件代号 Part No.	Description	零部件名称 Part name	数量 Quantity
1	11000-188	MOTOR ASSY	发动机总成	1
2	GB5787-2000	BOLT M6×12	螺栓 M6×12	1
3	100018-001	LEFT BRAND COVER	发动机装饰盖	1
4	161000-029	CARBURETOR ASSY	化油器	1
5	151100-003	OIL COOLING ASSY	油冷器	1
6	171000-039	AIR FILTER	空滤器	1
7	181000-124	MUFFLER ASSY	消声器	1
8	902001-010	HEXANGULAR AXLE 10*115	六角头轴 10*115	2
9	306810-005	EMERGENCY LIGHT CONTROLLER	应急灯控制器	1
10	303100-001	BATTERY ASSY	蓄电池	1
11	802000-012	FUEL SWITCH	燃油开关	1
12	302000-013	REGULATOR	调压整流器	1
13	308500-005	FUEL SENSOR	燃油传感器	1
14	304000-009	IGNITION COIL	点火线圈	1
15	307000-184	MAIN CABLE COMP	主电缆	1
16	301000-002	START RELAY	启动继电器	1
17	231000-027	CHAIN	链条	1
18	211000-029	SHIFTING PEDAL	换挡踏板	1
19	510002-008	FRONT SUSPENSION,ENGINE	发动机前悬挂	2
20	510001-007	UP SUSPENSION,ENGINE	发动机上悬挂	1
21	162001-025	HIGH TEMPERATURE TUBE	高温管	1
22	GB5787-2000	BOLT M8×16	螺栓M8×16	2
23	GB6177-2000	NUT M8	螺母M8	2
24	309300-004	FAN CONTROLLER	风扇控制器	1
25	307000-184	MAIN CABLE COMP	主电缆	1

26	GB5787-2000	BOLT M8×95	螺栓M8×95	4
27	GB6187-2000	NUT M8	螺母M8	4
28	GB5787-2000	BOLT M6×20	螺栓M6×20	2
29	GB6187-2000	NUT M10	螺母M10	2
30	GB5787-2000	BOLT M6×16	螺栓 M6×16	2
31	GB5787-2000	BOLT M6×20	螺栓 M6×20	4
32	181001-001	GASKET EXHUAUST PIPE	排气管密封垫	1
33	GB5783-2000	BOLT M6×30	螺栓 M6×30	2
34	GB5783-2000	BOLT M6×25	螺栓 M6×25	2
35	GB5783-2000	BOLT M6×28	螺栓 M6×28	2
36	GB5787-2000	BOLT M6×12	螺栓 M6×12	2
37	160100-001	FUEL FILTER	燃油过滤器	1
38	152200-005	FAN	风扇	1
39	151200-008	OIL COOLING TUBE	油冷管	1
40	151200-009	OIL COOLING TUBE	油冷管	1
41	305000-018	CDI	点火器	1
42	185000-007		催化转化器	1
43	162200-002		油气分离器	1

BS300S-18发动机物料编码对应表

序号	零部件名称	英文名称	物料编码	图册序号	物料规格	物料描述
1	左曲轴箱部件	LEFT CRANKCASE ASSY	101100-001	FIG. 4-18	BS300S-18	
2	右曲轴箱部件	RIGHT CRANKCASE ASSY	101200-001	FIG. 4-17	BS300S-18	
3	左曲轴箱盖部件	LEFT CRANKCASE COVER ASSY	101300-001	FIG. 4-3	BS300S-18	
4	双头螺栓A	DOUBLE-HEAD SCREW A	101103-024	FIG. 4-30	BS300S-18	
5	机油过滤网弹簧	SPRING, OIL FILTER	101116-011	FIG. 9-4	BS300S-18	
6	滤网盖O形圈	O-RING	101118-007	FIG. 9-6	BS300S-18	
7	起动机机连接板	CONNECTING PLATE, START MOTOR	101123-001	FIG. 11-9	BS300S-18	
8	油道堵头	PLUG, OIL	101126-001	FIG. 4-28	BS300S-18	Φ26×6
9	内挡圈	CTRCLIP	101127-004	FIG. 4-29	BS300S-18	Φ28
10	内挡圈	CTRCLIP	101127-005	FIG. 4-29	BS300S-A	Φ28
11	机油过滤网组合	ENGINE OIL FILTER ASSY	101130-008	FIG. 9-3	BS300S-18	
12	通气管	AIR DRAIN	101202-019	FIG. 2-12	BS300S-18	
13	通气管夹簧	HOOP, AIR DRAIN	101203-012	FIG. 2-13	BS300S-18	
14	通油螺栓	BOLT, OIL DRAIN	101206-004	FIG. 9-11	BS300S-18	M10
15	内油管组合	OIL PIPE UNIT 1	101230-005	FIG. 9-13	BS300S-18	
16	左曲轴箱后盖/轴传动箱盖	REAR PART, LEFT CRANKCASE COVER	101302-179	FIG. 4-42	BS300S-18	
17	左曲轴箱后盖/轴传动箱盖	REAR PART, LEFT CRANKCASE COVER	101302-180	FIG. 4-19	BS300S-16	
18	左曲轴箱前盖密封垫	LEFT CRANKCASE COVER GASKET	101304-020	FIG. 4-1	BS300S-18	
19	右曲轴箱盖	RIGHT CRANKCASE COVER ASSY	101401-296	FIG. 4-11	BS300S-18	
20	右曲轴箱盖密封垫	RIGHT CRANKCASE COVER GASKET	101403-025	FIG. 4-13	BS300S-18	
21	右盖轴承压板	PLATE, BEARING	101417-001	FIG. 3-20	BS300S-18	
22	油面镜组合	OBSERVE ASSY	101430-008	FIG. 4-44	BS300S-A	
23	机油尺组合	OIL DIPSTICK UNIT	101440-001	FIG. 4-15	BS300S-18	
24	机油尺O形圈	O-RING	101442-009	FIG. 4-16	BS300S-18	Φ19×2.4
25	缸体减震胶块(小)	DAMPER	102101-001	FIG. 3-28	BS300S-18	
26	气缸体密封胶垫	CYLINDER SHIM	102108-035	FIG. 3-24	BS300S-18	
27	气缸体组合	CYLINDER UNIT	102120-068	FIG. 3-23	BS300S-18	
28	气缸头左盖组合	L. COVER CYLINDER HEAD	102205-001	FIG. 2-10	BS300S-18	
29	气门盖	COVER AIR VALVE	102207-018	FIG. 2-18	BS300S-18	
30	气门盖	COVER AIR VALVE	102207-019	FIG. 2-19	BS300S-18	
31	气门盖O形圈	O-RING	102208-006	FIG. 2-20	BS300S-18	Φ56.2×2.4
32	油道O形圈	O-RING	102209-001	FIG. 3-25	BS300S-18	Φ13×2.5
33	油道O形圈	O-RING	102209-002	FIG. 1-18	BS300S-18	Φ8.8×1.9
34	缸头左侧盖O形圈	O-RING	102211-006	FIG. 2-14	BS300S-18	Φ105×2
35	挡油盘组合	OIL PENDER COVER UNIT	102212-002	FIG. 2-11	BS300S-18	

36	减震垫	ABSORBER GASEKT	102213-001	FIG. 2-6	BS300S-18	12×16×8
37	凸轮轴限位板	RESTRICT PLATE	102215-001	FIG. 2-24	BS300S-18	
38	摇臂轴压板		102216-001	FIG. 2-22	BS300S-18	
39	气缸头螺母/盖形螺母	CAP NUT	102218-013	FIG. 2-7	BS300S-18	M8
40	盖形螺母铜垫圈	WASHER	102219-007	FIG. 2-8	BS300S-18	Φ8
41	挡油盘O形圈	O-RING	102225-002	FIG. 2-16	BS300S-18	Φ91×3
42	气缸头密封垫组合	CYLINDER CAP SHIM UNIT	102230-048	FIG. 2-4	BS300S-18	
43	气缸头组合	CYLINDER HEAD ASSEMBLY	102240-323	FIG. 2-1	BS300S-18	
44	火花塞组合	SPARK PLUG	102250-019	FIG. 2-25	BS300S-18	
45	活塞	PISTON	103101-046	FIG. 3-3	BS300S-18	
46	活塞销	PISTON PIN	103102-024	FIG. 3-7	BS300S-18	
47	活塞销挡圈	CIRCLIP, PISTON PIN	103103-019	FIG. 3-8	BS300S-18	
48	第一道活塞环	PISTON RING 1	103104-037	FIG. 3-4	BS300S-18	
49	第二道活塞环	PISTON RING 2	103105-035	FIG. 3-5	BS300S-18	
50	油环组合	OIL RING ASSY	103110-010	FIG. 3-6	BS300S-18	
51	曲柄连杆部件	CRANK CONNECTING ROD ASSY	103200-082	FIG. 3-1	BS300S-18	
52	曲柄连杆部件	CRANK CONNECTING ROD ASSY	103200-083	FIG. 3-1	BS300S-A	
53	半圆键/圆柱销	WOODRUFF KEY	103203-014	FIG. 3-2	BS300S-18	3×5×10
54	半圆键/圆柱销	WOODRUFF KEY	103203-015	FIG. 3-16	BS300S-18	5×5.7×12
55	半圆键/圆柱销	WOODRUFF KEY	103203-016	FIG. 3-2	BS300S-A	5×4.6×12
56	曲柄左油封	LEFT OIL SEAL	103224-006	FIG. 4-32	BS300S-18	Φ28×Φ40×8
57	平衡轴	BALANCE SHAFT	103301-001	FIG. 3-11	BS300S-18	
58	平衡轴主动齿轮	DRIVE GEAR, BLANCE SHAFT	103302-006	FIG. 3-9	BS300S-18	
59	平衡轴从动齿轮	DRIVEN GEAR, BLANCE SHAFT	103303-006	FIG. 3-13	BS300S-18	
60	平键	FLAT KEY	103304-006	FIG. 3-12	BS300S-18	5×5×8
61	锁紧垫圈	LOCKING WASHER	103305-005	FIG. 3-14	BS300S-18	Φ14
62	锁紧螺母	NUT	103306-004	FIG. 3-15	BS300S-18	
63	挡圈26	CIRCLIP 26	103307-003	FIG. 3-18	BS300S-18	Φ26
64	正时链条垫圈	WASHER	104109-001	FIG. 1-4	BS300S-18	Φ10×Φ21×3
65	凸轮轴组合	CAMSHAFT UNIT	104130-048	FIG. 1-1	BS300S-18	
66	正时链条组合	TIMING CHAIN	104150-017	FIG. 1-5	BS300S-18	
67	正时从动链轮组合	DRIVEN SPROCKET, TIMING	104170-001	FIG. 1-2	BS300S-18	
68	张紧器部件	CHAIN TENSIONER	104200-009	FIG. 1-8	BS300S-18	
69	张紧器密封垫	SHIM OF TENSIONER	104209-008	FIG. 1-9	BS300S-18	
70	链条张紧板组合	PLATE, TENTORNER	104240-001	FIG. 1-7	BS300S-18	
71	链条导向板组合	PLATE, CHAIN ORIENTED	104250-001	FIG. 1-6	BS300S-18	
72	进气门	AIR INTAKE VALVE	104301-027	FIG. 1-12	BS300S-18	
73	排气门	AIR EXHAUST VALVE	104302-027	FIG. 1-22	BS300S-18	

74	气门内弹簧	VALVE INNER SPRING	104303-016	FIG. 1-14	BS300S-18	
75	气门外弹簧	VALVE OUTER SPRING	104304-016	FIG. 1-23	BS300S-18	
76	气门外弹簧座圈	VALVE SPRING SEAT	104306-013	FIG. 1-16	BS300S-18	
77	气门弹簧座	VALVE SPRING COVER	104307-016	FIG. 1-13	BS300S-18	
78	气门锁夹	VALVE LOCK CLIP	104308-015	FIG. 1-17	BS300S-18	
79	挡油罩组合	VALVE STEM OIL SEAL	104310-015	FIG. 1-15	BS300S-18	
80	气门摇臂组合/上摇臂组合	ARM ROCKER ASSY	104410-017	FIG. 1-21	BS300S-18	
81	气门摇臂轴	ROCKER ARM SHAFT	104413-016	FIG. 1-19	BS300S-18	
82	气门摇臂轴	ROCKER ARM SHAFT	104413-017	FIG. 1-20	BS300S-18	
83	机油泵密封垫	OIL PUMP PAD	105104-008	FIG. 9-2	BS300S-18	
84	机油泵组合	ENGINE OIL PUMP	105110-040	FIG. 9-1	BS300S-18	
85	机油滤清器部件	ENGINE OIL FINE FILTER	105200-014	FIG. 9-7	BS300S-18	
86	通油管	EX-TUBE, OIL	105202-005	FIG. 3-21	BS300S-A	
87	通油管弹簧	SPRING, EX TUBE	105203-005	FIG. 3-20	BS300S-A	
88	机油过滤器盖	COVER OIL FILTER	105206-003	FIG. 9-5	BS300S-18	
89	过滤器盖O形圈	O-RING	105211-004	FIG. 9-9	BS300S-18	Φ 53.5×2.3
90	机油过滤器盖组合	LUBRICATING L/O FILTER COVER ASSY	105230-001	FIG. 9-8	BS300S-18	
91	离合器组件	CLUTCH COMP	106000-064	FIG. 5-1	BS300S-A	
92	主动齿轮	DRIVE GEAR	106001-024	FIG. 3-18	BS300S-A	
93	止退垫圈	STOP WASHER, CLUTCH	106102-006	FIG. 5-2	BS300S-18	Φ 26
94	端盖密封垫	GASKET, END COVER	106109-004	FIG. 2-3	BS300S-18	
95	螺母	NUT	106111-001	FIG. 5-4	BS300S-18	M22×1
96	螺母	NUT	106111-002	FIG. 5-9	BS300S-18	M14×1
97	内舌止动垫圈	INTERNAL TAB WASHER	106116-001	FIG. 5-8	BS300S-18	Φ 14
98	内舌止动垫圈	INTERNAL TAB WASHER	106116-002	FIG. 5-3	BS300S-18	Φ 22
99	离合器分离板	PLATE RAMP	106117-001	FIG. 4-12	BS300S-18	
100	凸轮盘组合	CAMSHAFT ASSY	106130-001	FIG. 5-13	BS300S-18	
101	分离凸轮下板	LOWER CAM PLATE ASSY	106132-004	FIG. 5-11	BS300S-18	
102	钢球架组合	STEEL BALL BRACKET ASSY	106150-005	FIG. 5-12	BS300S-18	
103	离合器主体/主离合器部件	MAIN CLUTCH	106200-001	FIG. 5-5	BS300S-18	
104	钢球	STEEL BALL	106209-002	FIG. 5-2	BS300S-A	Φ 7.9
105	操纵杆弹簧	COMPRESSION SPRING	106301-011	FIG. 5-6	BS300S-A	
106	操纵杆油封	OIL SEAL	106303-006	FIG. 4-38	BS300S-18	Φ 12×Φ 22×5
107	拉筋定位板	LOCATING PLATE UNIT	106304-001	FIG. 3-22	BS300S-A	
108	调整螺钉	ADJUSTING SCREW	106307-005	FIG. 5-20	BS300S-18	
109	调节螺母	LOCKING NUT	106308-004	FIG. 5-22	BS300S-18	M8
110	调节螺钉O形圈	O-RING	106309-004	FIG. 5-21	BS300S-18	
111	调节螺钉平垫圈	WASHER	106311-003	FIG. 5-18	BS300S-18	Φ 8

112	操纵杆销钉/开口销	COTTER PIN	106312-007	FIG. 5-19	BS300S-18	Φ1.4×16
113	离合推杆	PUSH ROD, CLUTCH	106313-007	FIG. 5-7	BS300S-18	
114	支撑座	SUPPORT SEAT	106316-002	FIG. 5-17	BS300S-18	
115	连接销	CONNECTING PIN	106317-002	FIG. 5-16	BS300S-18	
116	离合器操纵杆组合	OPERATION ROCKER ARM UNIT	106320-016	FIG. 5-4	BS300S-A	
117	离合器操纵杆	OPERATION ROCKER ARM	106321-001	FIG. 5-14	BS300S-18	
118	初级离合器部件	PRIMARY CLUTCH ASSY	106500-004	FIG. 5-1	BS300S-18	
119	主轴部件	MAIN SHAFT ASSY	107100-054	FIG. 7-1	BS300S-18	
120	副轴部件	ASSEMBLY, COUNTERSHAFT	107200-071	FIG. 7-5	BS300S-18	
121	主轴油封	MAIN AXLE OIL SEAL	107115-003	FIG. 7-3	BS300S-18	Φ15×Φ28×3.5
122	副轴油套	COUNTER SHAFT BUSH	107217-002	FIG. 4-23	BS300S-18	
123	副轴压板	PRESSURE PLATE	107220-002	FIG. 7-2	BS300S-16	
124	主动锥轮	DRIVE SPROCKET	107221-027	FIG. 4-40	BS300S-18	520-14T
125	副轴油封	COUNTERSHAFT OIL SEAL	107230-016	FIG. 4-39	BS300S-18	Φ30×Φ45×8
126	副轴油封	COUNTERSHAFT OIL SEAL	107230-017	FIG. 3-22	BS300S-18	Φ17×Φ29×5
127	后盖O形圈	O-RING	107309-005	FIG. 7-10	BS300S-16	Φ56.2×2.4
128	惰轮齿组合	ASSEMBLY IDLE GEAR COMP	107330-009	FIG. 7-6	BS300S-18	
129	倒档双联齿组合	REVERSE WHEEL GEAR 2	107340-010	FIG. 7-7	BS300S-18	
130	倒档双联轴	REVERSE AXLE	107341-004	FIG. 7-8	BS300S-18	
131	输出轴	OUTPUT SHAFT	107361-002	FIG. 7-9	BS300S-16	
132	输出主动齿轮	OUTPUT DRIVE GEAR	107362-001	FIG. 7-5	BS300S-16	
133	输出从动齿轮	OUTPUT DRIVEN GEAR	107363-001	FIG. 7-8	BS300S-16	
134	防松螺母	NUT	107364-001	FIG. 4-41	BS300S-18	M16×1
135	倒档操纵板拉索支架	BRACKET OF REVERSE GEAR ROPE	107402-003	FIG. 4-37	BS300S-18	
136	输出轴油封	OIL SEAL	107602-003	FIG. 7-14	BS300S-16	Φ25×Φ40×8
137	后盖	BEARING HOUSING	107603-003	FIG. 7-11	BS300S-16	
138	力向节	CROSS JOINT	242100-010	FIG. 7-15	BS300S-16	
139	定位板扭簧	RETURN SPRING, LOCATING PLATE	108101-012	FIG. 6-5	BS300S-18	
140	变速鼓组合	GEARSHIFT DRUM	108110-039	FIG. 8-1	BS300S-18	
141	换档左拨叉	SHIFT FORK1 (L)	108121-012	FIG. 8-2	BS300S-18	
142	换档中拨叉	SHIFT FORK2	108122-011	FIG. 8-3	BS300S-18	
143	换档右拨叉/换档拨叉	SHIFT FORK3 (R)	108123-011	FIG. 8-4	BS300S-18	
144	拨叉轴	SHORT SHIFT FORK AXLE	108126-011	FIG. 8-5	BS300S-18	
145			108126-012	FIG. 8-6	BS300S-18	
146	定位板组合	LOCATING PLATE UNIT	108130-016	FIG. 6-4	BS300S-18	
147	换档轴部件	SHIFT SHAFT ASSY	108200-029	FIG. 6-2	BS300S-18	
148	换档定位螺栓	GEAR SHIFTING FITTINGN BOLT	108201-001	FIG. 5-10	BS300S-18	
149	换档轴垫圈	WASHER	108208-004	FIG. 6-3	BS300S-18	

150	换挡板侧弹簧	SPRING, GEARSHIFT LEVER	108209-003	FIG. 5-15	BS300S-18	
151	超越离合器部件	CLUTCH OF ELECTRIC STARTER ASSY	109100-011	FIG. 11-7	BS300S-18	
152	双联齿挡圈	CIRCLIP	109205-002	FIG. 11-4	BS300S-18	Φ12
153	盘形齿轮/起动大链轮组合	GEAR UNIT OF ELECTRIC STARTER	109210-013	FIG. 11-6	BS300S-18	
154	大双联齿轴	DOUBLE GEAR SHAFT ASSY	109221-010	FIG. 11-2	BS300S-18	
155	大双联齿轮	BTG DOUBLE GEAR ASSY	109231-010	FIG. 11-1	BS300S-18	
156	起动棘轮O形圈	O-RING	109502-002	FIG. 10-4	BS300S-18	
157	起动棘轮垫圈	WASHER	109503-003	FIG. 10-5	BS300S-18	
158	手起动盖轴承压板	PRESSURE PLATE, BEARING	109504-001	FIG. 4-34	BS300S-18	
159	起动棘轮螺栓	BOLT, START RATCHET WHEEL	109505-001	FIG. 10-6	BS300S-18	M10×1.25×40
160	左侧盖组合	LEFT SIDE COVER UHIT	109530-003	FIG. 10-1	BS300S-18	
161	起动棘轮组合	STARTING RATCHET	109550-004	FIG. 10-3	BS300S-18	
162	磁电机组件	MAGNETO ASSY	111000-047	FIG. 11-11	BS300S-18	
163	起动机组件	STARTING MOTOR	112000-118	FIG. 11-8	BS300S-18	
164	档位显示部件	CABLE ASSEMBLY, GEAR INDICATION	113200-065	FIG. 8-7	BS300S-18	
165	档显O形圈	O-RING SHAFT INDICATION	113212-007	FIG. 4-22	BS300S-18	Φ19×2
166	螺栓	BOLT	115100-001	FIG. 4-24	BS300S-18	M6×50
167	螺栓	BOLT	115100-002	FIG. 4-25	BS300S-18	M6×32
168	螺栓	BOLT	115100-003	FIG. 4-26	BS300S-18	M6×160
169	螺栓	BOLT	115100-004	FIG. 4-27	BS300S-18	M6×35
170	螺栓	BOLT	115100-005	FIG. 4-6	BS300S-18	M6×25
171	螺栓	BOLT	115100-006	FIG. 4-8	BS300S-18	M6×40
172	螺栓	BOLT	115100-007	FIG. 11-10	BS300S-18	M6×15
173	螺栓	BOLT	115100-008	FIG. 10-2	BS300S-18	M6×20
174	螺栓	BOLT	115100-009	FIG. 2-2	BS300S-18	M6×10
175	螺栓	BOLT	115100-010	FIG. 2-15	BS300S-18	M6×12
176	螺栓	BOLT	115100-011	FIG. 2-17	BS300S-18	M6×10
177	螺栓	BOLT	115100-012	FIG. 2-23	BS300S-18	M6×18
178	螺栓	BOLT	115100-013	FIG. 7-9	BS300S-18	M6×12
179	螺栓	BOLT	115100-014	FIG. 1-3	BS300S-18	M10×1.25×25
180	螺栓	BOLT	115100-015	FIG. 1-11	BS300S-18	M6×16
181	螺栓	BOLT	115100-016	FIG. 7-12	BS300S-16	M8×25
182	螺栓	SCREW	115200-001	FIG. 4-35	BS300S-18	M5×16
183	螺栓	SCREW	115200-002	FIG. 4-9	BS300S-18	M6×18
184	螺栓	SCREW	115200-003	FIG. 11-12	BS300S-18	M6×25
185	螺栓	SCREW	115200-004	FIG. 7-1	BS300S-16	M8×25
186	螺钉	SCREW	115200-005	FIG. 5-7	BS300S-A	
187	弹簧垫圈	HELICAL SPRING LOCKWASHER	115300-001	FIG. 11-13	BS300S-18	Φ6

188	内六角螺栓	DAMPER	115400-001	FIG. 3-27	BS300S-18	M6×25
189	内六角螺栓	DAMPER	115400-002	FIG. 2-9	BS300S-18	M8×45
190	内六角螺栓	DAMPER	115400-003	FIG. 2-21	BS300S-18	M6×18
191	螺栓	BOLT	116101-001	FIG. 9-10	BS300S-18	M6×25
192	定位销	ALIGNMENT PIN	116108-001	FIG. 4-36	BS300S-18	Φ8×14
193	定位销	ALIGNMENT PIN	116108-002	FIG. 4-2	BS300S-18	Φ12×16
194	定位销	ALIGNMENT PIN	116108-003	FIG. 3-26	BS300S-18	Φ12×16
195	定位销	ALIGNMENT PIN	116108-004	FIG. 4-23	BS300S-16	Φ10×14
196	垫圈	WASHER	116109-001	FIG. 4-31	BS300S-18	Φ12×Φ22×2
197	垫圈	WASHER	116109-002	FIG. 4-21	BS300S-18	
198	垫圈	WASHER	116109-003	FIG. 11-3	BS300S-18	Φ12
199	垫圈	WASHER	116109-004	FIG. 9-12	BS300S-18	Φ10
200	垫圈	WASHER	116109-005	FIG. 7-4	BS300S-16	
201	垫圈	WASHER	116109-006	FIG. 5-8	BS300S-A	Φ8
202	轴承	BEARING	116210-001	FIG. 5-6	BS300S-18	6000
203	轴承	BEARING	116210-002	FIG. 4-33	BS300S-18	60/28
204	轴承	BEARING	116210-003	FIG. 4-19	BS300S-18	6304/P5
205	轴承	BEARING	116210-004	FIG. 3-10	BS300S-18	6304
206	轴承	BEARING	116210-005	FIG. 3-17	BS300S-18	6306/P5
207	轴承	BEARING	116210-006	FIG. 3-21	BS300S-18	6203
208	轴承	BEARING	116210-007	FIG. 7-2	BS300S-18	6204/P6
209	轴承	BEARING	116210-008	FIG. 7-4	BS300S-18	6202/P6
210	轴承	BEARING	116210-009	FIG. 7-13	BS300S-16	6305/P5CS16
211	滚针轴承	NEEDLE ROLLER BEARING	116220-001	FIG. 5-5	BS300S-A	HK142012